

無線電製作

售價港幣 \$2.00

1975增刊 3

ALL JAPANESE TRANSISTOR DATA MANUAL

- SECTION 1 LISTING OF ALL TRANSISTORS
- SECTION 2 SUBSTITUTION GUIDE
- SECTION 3 LISTING OF
FIELD EFFECT TRANSISTORS
(WITH AMERICAN TYPE INCLUDED);
APPLICATION CIRCUITS;
SUPPLEMENT TO SECTION 1;
TERMINATION DRAWINGS

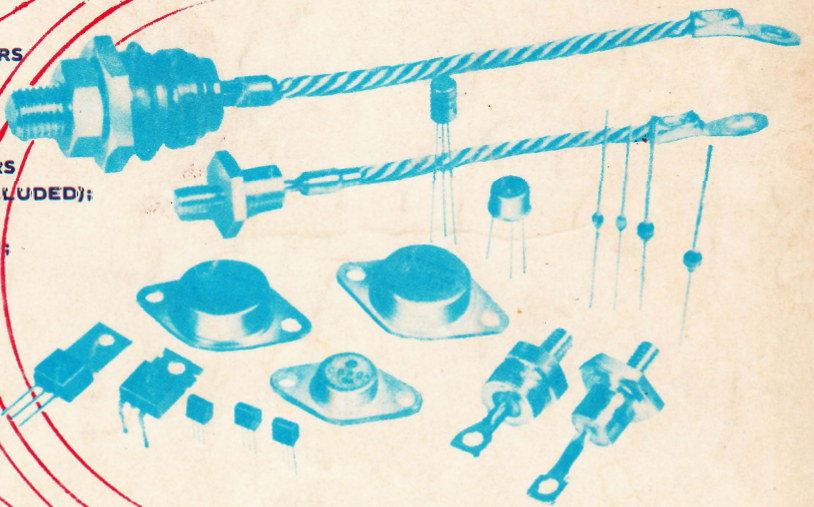

全日本晶體管一場效應管
特性資料與換用手冊
(下篇)

ALL JAPANESE TRANSISTOR DATA MANUAL

全日本晶體管一場效應管 特性資料與換用手冊

INTRODUCTION

Although primarily intended to provide technical information to assist in the using and identification of Japanese bipolar transistors and FET's, this book has a special interest to the professional engineer and technician as a general work of guidance in the selection of Japanese transistors for particular applications. The guide to possible alternatives of different manufactures in Section 2 is probably the most comprehensive.

The following colours are used in the printing of this book to assist in locating the required section.

Section 1	Listing of All Bipolar Transistors	Black
Section 2	Substitution Guide of Bipolar Transistors	Blue
Section 3	Listing of FET's (with American type included)	Brown
	Application Circuits of FET;	Brown
	Supplement to Section 1;	Black
	Termination Drawings of Transistor	Black

本書臚列了全部日製的普通晶體管之詳盡技術數據，足供一切專業上之使用及設計上之參考，全書分為三大部份，並以不同顏色印刷，以便於索查。

上篇：全日本晶體管特性資料（黑色）

中篇：各廠晶體管的互換（藍色）

下篇：全日本場效應管特性資料及接腳識別（附美式管特性，棕色）；場效應管典型應用綫路（棕色）；晶體管特性補篇及接腳識別圖（黑色）。

無綫電製作 1975 年增刊③
1975 年 11 月 20 日出版
中華民國六十四年

編輯者 無綫電製作出版社 電話 3-654837 地址
香港九龍土瓜灣道 297 號三樓·督印人 林秋和·承
印者 華生印刷廠 九龍新蒲崗彩虹道 202 號二樓·

香港總代理 同德書報社 九龍砵蘭街 269 號 電話
3-962751·星馬總代理 東亞文化事業有限公司
星加坡大坡馬路 167 號 電話 76376·台灣總代理
雨辰書報社 台灣台北市中華路二段 75 巷一弄 26
號 電話 3811897 郵政劃撥儲金第 13165 號雨辰書
報社·印尼區代理 椰城集源公司 TOKO SUM-
BER ANEKA JL. TIANG BENDER 87A,
JAKARTA-KOTA, INDONESIA.

Section 3

LISTING OF FIELD EFFECT TRANSISTORS

(下篇)

美、日場效應管特性及接綫圖

場效應晶體管專用名詞說明

場效應晶體管 (FET)，所用的符號與專用名詞，是和一般晶體管所用的不相同，故此當我們閱讀有關場效應晶體管的書籍時，便會感覺不習慣，同時場效應晶體管所用的名詞和符號，現在還未完全統一，各廠有他們獨特的符號和名詞，現在將其中主要使用的符號和名詞，簡單地說明。

首先是表示與耐壓有關的最大規格值。

■ V_{GDS} (洩極—源極短路時閘極與洩極間的電壓)

V字後面所加的三個字，是用來表示有關的電極及測試的情況，這是與一般晶體管所使用的相同。第一個字是代表起點的電極，第二個字是代表輸入和輸出的共通電極（或代表接地電極），最後第三個字，是代表第三個電極與共通電極的情況，例如。

- S代表短路；
- O代表開路；
- X代表加接指定的偏壓；
- R代表接上指定的電阻。

閘極與洩極間的耐壓值，普通用於結面型的場效應晶體管，是相當於閘極與洩極間的PN結的擊穿電壓值，如果使用得超過規定的反向電壓時，便會進入擊穿電壓領域，反向電流便會急劇增加，以致PN結破壞，故此在設計使用時，希望能使用廠方的保證最大規格內的數值，否則很容易使晶體管損壞。

除了 V_{GDS} 外還有 V_{GDO} 、 V_{GDX} 等均是代表閘極與洩極間的耐壓值，普通的結型FET，在內部的構造上，閘極對洩極和源極是對稱的，所以 $V_{GDS} \cong V_{GDO} \cong V_{GDX}$ 。

■ V_{DSX} (洩極與源極間的電壓)

主要是使用於MOS型的場效應

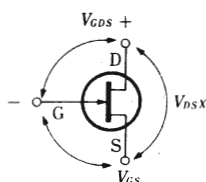

圖(1) V_{GDS} 與 V_{DSX} 的關係

晶體管上，因為MOS型場效應晶體的閘極與洩極間的耐壓，是相當於氧化膜的耐壓，在實際電路上，是與洩極和源極間的耐壓無直接關係。在結型的場效應晶體管方面， V_{GDS} 與 V_{DSX} 成爲下面所寫的關係式， $V_{DSX} \cong V_{GDS} - V_{GS}$ 。

這種情形在圖(1)中可以看出來，實際可能加在洩極與源極間的電壓，是因閘極與源極間的偏壓而異，但是一定要較 V_{GDS} 爲小。在截斷時的最小電壓是(V_{DSX})最小 = $V_{GDS} - |V_p|$ ，這算式內的 V_p 是夾斷電壓，是表示在截斷時的偏壓值。普通來講 V_{DSX} 是表示在截斷時的耐壓值，但是一如上述的情況，我們要加以留意， V_{DSX} 並不相當於 V_{GDS} ，而是由 V_{GDS} 減去夾斷電壓(V_p)的數值，才是它的實際耐壓值。

■ V_{GSO} (閘極與源極間的電壓)

這是用於MOS型場效應晶體管上的參數，與用於普通半導體管上的 V_{EBO} 的參數一樣，是特別爲開關電路試測用。

■ I_G (閘極電流)

在結型場效應晶體管方面，倘若閘極與源極間，加上順向的偏壓時，便開始有閘極電流流動，這種情形是與普通的晶體管一樣，這時的洩極電流值，是較 I_{DSS} 的數值大，可是由於要受制於洩極方面的損耗容許值，所以首先要選定最大的順向電流值，

在MOS型的場效應晶體管方面，因爲在構造上不同的緣故，對於順向的閘極電流是不存在的，因此普通是以 I_D 的最大值，來代替 I_G 的最大值。

■ Pd (容許損耗值)

這是與普通的晶體管所用的 P_c 值一樣，是用來表示當在 25°C 時的最大容許損耗值，同時因爲是通道的消耗，所以也有用 P_{ch} (容許通道損耗值)來表示。

■ T_j (接合面的溫度)

通常是用於結型的場效應晶體管上，它是和普通晶體管所用的 T_j 是同樣意思，至於用在MOS型的場效應管方面，則以 T_{ch} (通道溫度值)來表示。

跟着是談對於電氣的特性方面的有關術語。

■ I_{GSS} (閘極截斷電流)

這是對於輸入阻抗有關的參數，是當閘極與源極短路時，在閘極與源極間加上逆電壓時的洩漏電流值，可參考圖(2)。

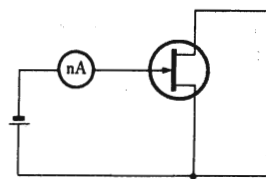

圖(2)測量 I_{GSS} 的綫路(N通道管)

在結型場效應管方面， I_{GSS} 是相當於PN結的逆方向電流；在MOS型的場效應管方面，則與結型的大不相同，只是通過氧化膜的電流，但是所流的電流是很微小的，反而在試測時由插座所流的電流，及零件本身的洩漏電流，及外殼的洩漏電流，還比較大得多。

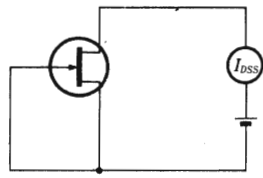

圖(3) 測量 I_{DSS} 的綫路 (N通道管)

■ I_{DSS} (洩極電流值)

是當閘極與源極短路，亦即是零偏壓時的洩極電流值，這時所選的洩極與源極間的電壓，遠比夾斷電壓的絕對值為大，比較擊穿電壓為小及使電流充份飽和的數值，可參考圖(3)。

圖(4)是場效應管的靜特性分類圖，其中分

- (a) 耗盡型，
- (b) 耗盡型+增強型，
- (c) 增強型，

等共三類，(a)和(c)的 I_{DSS} 的大小是對稱的，亦即是在耗盡型方面， I_{DSS} 是相當於最大電流飽和值，表示出最大的數值，而在增強型方面，則變為截止電流值，成為最小的數值。

■ V_p (夾斷電壓值)

這個參數是適用於(a)與(b)型上，是表示當在一定的洩極與源極間電壓時，加大閘極的偏壓，使電流等於零時的閘極與源極間的電壓值，除了 V_p 外，亦有用 V_{GS} 和 $V_{GS(off)}$ (叫做閘極與源極間的截止電壓) 來表示，可是在實際試測時，電流很難達到零值，只是盡量規定微小的電流值，各廠家的規定值，是不一樣的，普通是當 $I_D = 0.1 \mu A, 1 \mu A, 10 \mu A$

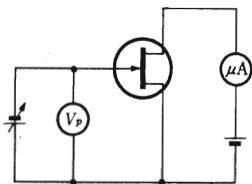

圖(5) 測量 V_p 的綫路

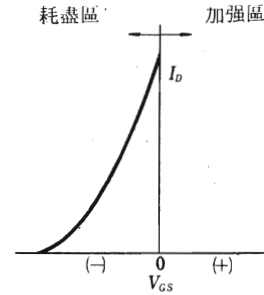

(a) 耗盡型管

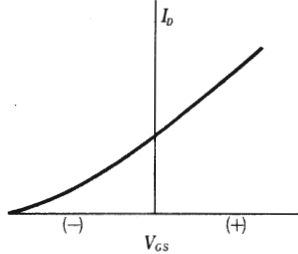

(b) 耗盡型+加強型管

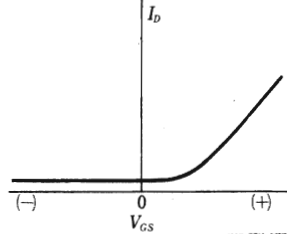

(c) 加強型管

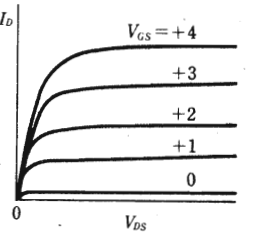
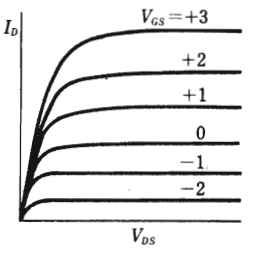
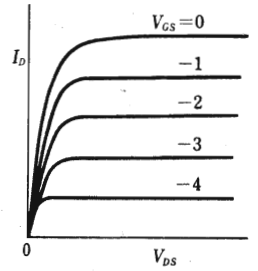

圖(4) FET的靜態特性的分類

時的偏壓值，可參考圖(5)。另一個是(c)增強型，它的電流開始流動點，不叫做 V_p ，是用 V_{th} 來表示 (V_{th} 是開啓電壓值)，可參考圖(6)。

■ g_m (互導率)

g_m 的定義用下面的數式表示，除 g_m 外，還有用 $|Y_{ro}|$ (源極接地的小訊號順傳導納) 來表示。

$$g_m = \left. \frac{\partial I_D}{\partial V_{GS}} \right|_{V_{DS} = \text{一定}}$$

偏壓方面，多數是採用與 I_{DSS} 所

用的條件相同，首先是採用規定的洩極電流值，試測時所用的電路圖，可參考圖(7)，普通是用 1KHz 來測試的。

■ g_{os} (輸出互導率)

除了 g_{os} 外，或有會採用 $|Y_{os}|$ 來表示，是相當於在電子管方面的 r_p (屏極電阻) 的倒數，輸出互導率通常是跟隨電流的大小而變化的，它的試測條件是和測試 g_m 時所用的相同

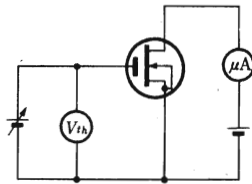

圖(6) 測量 V_{th} 的綫路

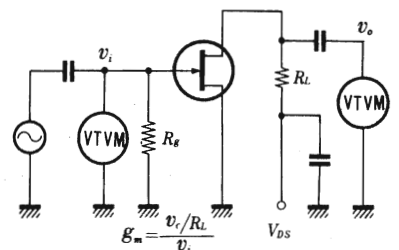

圖(7) 測量 g_m 的綫路

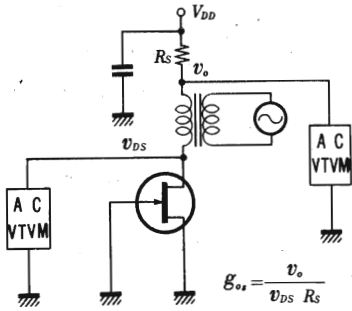

圖(8) 測量 g_{0s} 的綫路

，可參考圖(8)。

■ C_{i_s} (源極接地時的輸入電容值)

它的試測條件，各廠所用的是不相同，有各式各樣的方法，特別是結型的試測，輸入電容量，成為PN結間的逆偏壓容量，所以偏壓的所定條件，可以用大數值或小數值，多數是用零偏壓，亦即是試測 C_{i_s} 的最大值。測試的方法，可參考圖(9)。在洩極與源極間加上電壓，用電容電橋來試測，其中可分為2點式及3點式兩種，圖(9)是2點式，圖(10)是3點

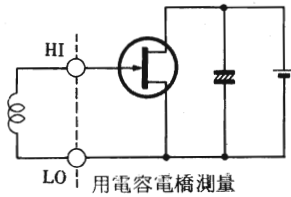

圖(9) 測量 C_{i_s} 的綫路(二點式)

式。這都是單純測試閘極與源極間的電容量的電路圖。

■ C_{r_s} (源極接地的回輸電容量)

這個參數是與低頻和高頻均有關係，在低頻方面，如果 C_{r_s} 數值大，則由於米勒效應的關係，等效的輸入電容量便增大，會降低上限的頻率數，在高頻電路方面，與 g_m 一齊的時候， C_{r_s} 的數值愈大，則對於高頻的特性愈好，即是 g_m/C_{r_s} 的數值愈大愈好，圖(11)便是 C_{r_s} 的測量電路圖。

■ R_{ON} (接通時電阻值)

R_{OFF} (斷路時的電阻值)

這兩個參數，主要是用於削波器(Chopper)的電路上。FET的靜特性曲綫的開始部份(三極管的區域)，與普通晶體管的相同，因為它是沒有偏移電壓的存在，故此它的電阻值，會因偏壓而起變化，所以可以當為一個可變電阻看。

在圖(12)中，可以看到，一系列

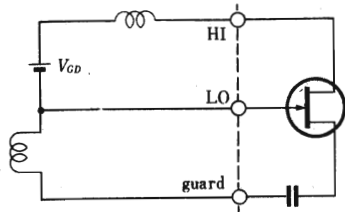

圖(11) 測量 C_{r_s} 的綫路(三點式)

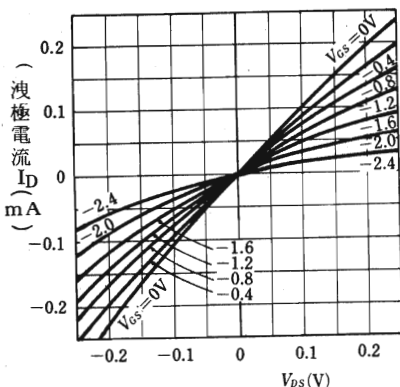

圖(12) $V_{DS} - I_D$ 特性的例子

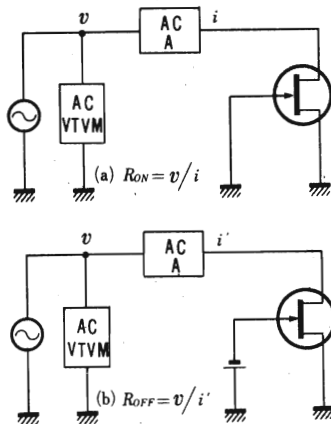

圖(13) 測量 R_{ON} 與 R_{OFF} 的綫路

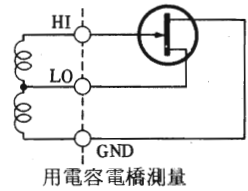

圖(10) 測量 C_{i_s} 的綫路(三點式)

的傾斜直綫；在這裡又可以見到當 $V_{GS} = 0$ ， V_{DS} 電壓一定時， I_D 電流最大，所以這時可以說是 R_{ON} ，至於當 I_D 在最小時，當然是屬於 R_{OFF} ，圖(13)是測量 R_{ON} 和 R_{OFF} 的電路圖。

簡稱及符號的說明

(1) 製造商名稱

富士通	富士通有限公司
三洋	東京三洋電機有限公司
東芝	東京芝浦電氣有限公司
日電	日本電氣有限公司
日立	日立製作所有限公司
三菱	三菱電機有限公司
新力	Sony 有限公司
松下	松下電子工業有限公司

(2) 構造

J	Junction (結型)型
MOS	Metal Oxide Semiconductor (金屬氧化型)
V	Vertical(縱型)

(3) 型式

D	耗盡型
E	加強型
D+E	耗盡型+加強型

(4) 區別

通工	通訊工業用
一般	一般用

日製場效應管用途分類表

類 型	型 號	用 途				直高 流輸 、入 交阻 流電 抗路	低 雜 音	低 頻 推 出	率 輸 出	攝 像 管 前 置 放 大 器	削 波 器 電 路	S W 電 路	可 變 電 阻 電 路	R F M I X	F M M I X	V H F 放 大	V H F 變 頻	
		社 名	構 造	方 式	區 分													
2SJ	2SJ18	SONY-	J (V)	D	一般			●										
	2SJ 19	日 電	J (V)	D	一般			●										
	2SJ 20	日 電	J (V)	D	一般			●										
2SK	2SK11	東 芝	J	D	通工	●	●			●	●							
	2SK12	東 芝	J	D	通工	●	●			●	●							
	2SK15	東 芝	J	D	通工	●	●											
	2SK16 ㊦	日 立	J	D	通工	●	●			●	●							
	2SK19	東 芝	J	D	一般							●	●	●	●	●	●	
	2SK23 A	SONY-	J	D	一般			●	●				●	●	●	●	●	
	2SK30 A	東 芝	J	D	一般	●	●	●					●	●	●	●	●	
	2SK33	三 菱	J	D	一般										●	●	●	
	2SK34	三 菱	J	D	一般	●	●	●						●				
	2SK37	日 電	J	D	一般										●			
	2SK38	三 菱	MOS	D+E		●												
	2SK39 A	SONY	J	D	一般	●												
	2SK40	日 立	J	D	一般	●	●	●										
	2SK41	三 洋	J	D	一般											●	●	
	2SK42	SONY	J	D	一般					●					●	●	●	
	2SK43	SONY	J	D	一般		●			●								
	2SK43 ㊤	SONY	J	D	通工	●	●				●							
	2SK43 ㊤-D	SONY	J	D	通工	●	●				●	●						
	2SK44	三 洋	J	D	一般	●	●	●										
	2SK45	日 電	J	D	通工	●	●	●				●	●					
	2SK46	三 菱	J	D	一般	●	●	●										
	2SK47	日 電	J	D	一般	●								●				
	2SK48	東 芝	J	D	通工	●	●											
	2SK49	日 電	J	D	一般											●	●	
	2SK50	松 下	J	D	一般	●												
	2SK54	日 立	J	D	一般										●	●	●	
	2SK55	日 立	J	D	一般										●	●	●	
	2SK56	松 下	J	D	一般										●	●	●	
	2SK	2SK60	SONY-	J	D	一般			●									
		2SK61	東 芝	J	D	一般										●	●	●
2SK69		日 電	J (V)	D	一般			●										
(2SK×2)	2SK70	日 電	J (V)	D	一般			●										
	MK10	三 菱	J	D	一般	●	●			●						●	●	
	2SK18	東 芝	J	D	通工	●												
(2SK×3)	2SK18 A	東 芝	J	D	通工	●												
	2SK72	東 芝	J	D	通工	●												
	μPA50A	日 電	J	D	一般			●										
3SJ	3SJ 11 A	日 電	MOS	E	通工	●					●							
	(3SJ×2) μPA33A	日 電	MOS	E	通工	●				●								
3SK	3SK14	日 電	MOS	D+E	通工	●				●								
	3SK20 ㊦	日 立	MOS	D+E	通工	●				●								
	3SK21 ㊦	日 立	MOS	D+E	通工	●				●								
	3SK22	東 芝	J	D	一般							●	●	●	●	●	●	
	3SK28	東 芝	J	D	通工	●	●		●			●				●	●	
	3SK29	日 電	MOS	D+E	通工	●				●								
	3SK30	日 立	J	D	一般									●	●	●	●	
	3SK30 A	日 立	J	D	一般									●	●	●	●	
	3SK38 A	東 芝	MOS	E	通工					●								
	(3SK×2) μPA34A	日 電	MOS	D+E	通工	●				●								
雙開極型 (3SK)	3SK35	東 芝	MOS	D+E	一般									●	●	●		
	3SK37	SONY	MOS	D+E	一般									●	●	●		
	3SK39	松 下	MOS	D+E	一般									●	●	●		
	3SK39 ㊧	松 下	MOS	D+E	通工									●	●	●		
	3SK40	日 電	MOS	D+E	一般									●	●	●		
	3SK44	東 芝	MOS	D+E	一般									●	●	●		
	3SK45	日 立	MOS	D+E	一般									●	●	●		
	3SK49	松 下	MOS	D+E	一般									●	●	●		
3SK49 ㊧	松 下	MOS	D+E	通工									●	●	●			



LISTING OF
FIELD EFFECT TRANSISTORS

場效應管特性表

電 気 的 特 性 (Ta=25°C)												其 他	外 形	型 名			
C _{rr} (pF)			C _{rr} (pF)			NF (f=1kHz, R _r =1MΩ)			NF (f=100MHz)								
typ	max	$\frac{V_{GS}(V)}{I_D(mA)}$	typ	max	$\frac{V_{GS}(V)}{V_{DS}(V)}$	typ	max	$\frac{V_{DS}(V)}{I_D(mA)}$	typ	max	$\frac{V_{DS}(V)}{I_D(mA)}$						
190		15	0									V _{ON} = -10Vmax (I _G = -0.2A, I _D = -3A, t = 100ms)	2SK60	45	2SJ18		
												$\mu = 10 \text{min}$ (V _{DS} = -10V, I _D = -10mA)	20K69	41	2SJ19		
710		-100	-10										20K70	42	2SJ20		
3	5	-10	0											2	2SK11		
3	5	-10	0											2	2SK12		
3	5	-10	0									(R _g = 10kΩ)		2	2SK15		
9		-1	6	2		-6	0	0.15V/√Hz	6	0.5		V _{N(p-p)} = 4 μVmax (V _{DS} = 5V, I _D = 0.45mA, R _g = 10kΩ, Δf = 2-50Hz)	R _{ON} = 350Ω typ (V _{DS} = 0.1V, V _{GS} = 0)	3	2SK16		
4		0	0	0.45	0.8	-10					2.0	3.5	$\frac{10}{(V_{DS})}$	PG = 20dB typ (f = 100MHz)	4	2SK19	
5		0	10	1.8	0	10		12.5nV/√Hz	10	I _{DSS}	2	10	I _{DSS}	PG = 18dB typ (f = 100MHz)	5	2SK23A-4	
5		0	10	1.8	0	10		12.5nV/√Hz	10	"	2	10	"	PG = 18dB typ (f = 100MHz)	5	2SK23A-5	
5		0	10	1.8	0	10		12.5nV/√Hz	10	"	2	10	"	PG = 18dB typ (f = 100MHz)	5	2SK23A-6	
8.2		0	0	2.6		-10	0	$\frac{(f=120\text{Hz}, R_g=100k\Omega)}{0.5, 5.0}$	15	"					7	2SK30A	
				0.5		0	10				2.5		$\frac{10}{(V_{DS})}$	PG = 20dB typ (f = 100MHz)	8	2SK33	
8		0	10	1.5		0	10	$\frac{(f=100\text{Hz}, R_g=100k\Omega)}{3.0, 6.0}$	10	0.1					9	2SK34	
				1	1.5	0	5								10	2SK37	
6		0	0												11	2SK38	
															12	2SK39A	
6.7		0	15	1.6		0	15	$\frac{(f=120\text{Hz}, R_g=100k\Omega)}{1, 5}$	15	I _{DSS}					13	2SK40	
				0.35	0.75	0	10					3.5	10	3	PG = 22dB typ (f = 100MHz)	14	2SK41
				0.085	0.12		4					2.5	4	I _{DSS}	PG = 12dB min (f = 100MHz)	15	2SK42
13		0	10	2.4		0	10	12nV/√Hz	$\frac{(R_g=10k\Omega)}{10}$	I _{DSS}					16	2SK43	
13		0	10	2.4		0	10	12nV/√Hz	$\frac{(R_g=10k\Omega)}{10}$	I _{DSS}					16	2SK43	
13		0	10	2.4		0	10	12nV/√Hz	$\frac{(R_g=10k\Omega)}{10}$	I _{DSS}				R _{ON} = 80Ω max (V _{DS} = 0.1V, V _{GS} = 0)	16	2SK43	
															28	2SK44	
4	5.5	0	5	1	1.5	0	5	$\frac{(f=1\text{MHz})}{1.5}$	5	0.5					30	2SK45	
8		0	10	1.5		0	10	$\frac{(f=100\text{Hz}, R_g=100k\Omega)}{3, 6}$	10	0.1					20	2SK46	
4.5		0	5	1.5	2	0	5								18	2SK47	
				5	8	-10	0	$\frac{(f=120\text{Hz}, R_g=100k\Omega)}{0.5, 5}$	10	0.45			V _{N(p-p)} = 4 μVmax (V _{DS} = 5V, I _D = 0.45mA, R _g = 10kΩ, Δf = 5-50Hz)	2	2SK48		
5	6.5	0	5	0.07	0.25	0	5				3.5	6	5	I _{DSS}	PG = 18dB typ (f = 100MHz)	40	2SK49
															36	2SK50	
3		0	10	0.4	0.6	0	10				2.0	3.5	$\frac{10}{(V_{DS})}$	PG = 15dB typ (f = 100MHz)	37	2SK54	
3		0	10	0.4	0.6	0	10				2.0	3.5	$\frac{10}{(V_{DS})}$	PG = 18dB typ (f = 100MHz)	37	2SK55	
4		0	5	0.1		0	5				4.5	5	1	PG = 12dB min (f = 100MHz)	38	2SK56	
190		-15	0											V _{ON} = 10Vmax (I _G = 0.2A, I _D = 3A, t = 100ms)	2SJ18	45	2SK60
				0.1	0.15	-10					2.5	3.5		PG = 18dB typ (f = 100MHz)	4	2SK61	
														$\mu = 10 \text{min}$ (V _{DS} = 10V, I _D = 10mA)	41	2SK69	
430		100	10												42	2SK70	
															9	MK10	
6		V _{GS} = 0		2.5	-10	0		$\Delta V_{GS1} - V_{GS2} / \Delta T_s = 100\mu\text{V}/^\circ\text{C}$	max	$\frac{(V_{DS}=10\text{V}, I_D=200\mu\text{A})}{(T_s=0-60^\circ\text{C})}$					19	2SK18	
6		"		2.5	-10	0		= 20μV/°C	"	"					19	2SK18A	
9		-10	0											$\Delta V_{GS} = 10\text{mV max}$ (V _{DS} = 10V, I _D = 0.05, 0.2, 0.4mA)	43	2SK72	
5		Q ₁ , Q ₂	1	10	1.3	Q ₁ , Q ₂	2	1mA	10	$\frac{(f=10\text{Hz})}{30}$	60nV/√Hz	10	1	$\Delta I_{DSS} = 10\% \text{max}$ (V _{DS} = 10V)	44	μPA50	
8		0	-10											R _{ON} = 500Ω max (V _{DS} = -1V, V _{GS} = -10V)	23	3SJ11A	
15	20	20	0					R _{ON} = 500Ω max $\frac{(V_{DS} = -0.1\text{V})}{(V_{GS} = -6\text{V})}$	$\Delta V_{IS} = 0.2\text{V}$ $\frac{(V_{DS} = -10\text{V})}{(I_D = -10\mu\text{A})}$	$\Delta g_m = 10\% \text{max}$ $\frac{(V_{DS} = -10\text{V})}{(I_D = -1\text{mA})}$					22	μPA33A	
3		0	10								5	10	1		23	3SK14	
5		0	6												26	3SK20	
5		0	6											R _{ON} = 300Ω max (V _{DS} = 0.1V, V _{GS} = V _{GS2} = 0), R _{OFF} = 100MΩ min (V _{DS} = 0.1V, V _{GS} = -6V, V _{GS2} = 0)	26	3SK21	
3		0	0	0.4	0.6	-10					2	3.5	$\frac{10}{(V_{DS})}$	PG = 20dB typ (f = 100MHz)	27	3SK22	
		6	0	10		0.6	-10				2.5	10	I _{DSS}	PG = 17dB min (f = 100MHz)	27	3SK28	
3		0	10												23	3SK29	
5		0	10	0.4	0.6	0	10				2.0	3.5	$\frac{10}{(V_{DS})}$	PG = 17dB typ (f = 100MHz)	29	3SK30	
5		0	10	0.4	0.6	0	10				2.0	3.5	$\frac{10}{(V_{DS})}$	PG = 17dB typ (f = 100MHz)	29	3SK30A	
	2.5	0	0			2.5	0	0						$\Delta C_G = 0.3\text{pF max}$ R _{ON} = 500Ω max (V _{DS} = 10mA, V _{IS} = 3V)	31	3SK38A	
4		0	10											$\Delta I_{DSS} = 0.1\text{mA max}$ $\frac{(V_{DS} = 10\text{V})}{(V_{GS} = 0)}$	22	μPA34A	

雙開極型	社名	構造	最大定格 (T _a =25°C)						電氣的特性 (T _a =25°C)														
			V _{GS}	V _{DS}	V _{GS0}	I _D	P _d	T _{st}	I _{CSS}	I _{DSS} (mA)		V _{DS}	V _{PI}	V _{DS}	V _{PI2}	V _{DS}	g _m (mΩ)			V _{DS}	I _D	g _{os} (mΩ)	
			(V)	(V)	(V)	(mA)	(mW)	(°C)	(nA)	max	min	max	(V)	(V)	(V)	(V)	(V)	min	typ	max	(V)	(mA)	typ
3SK35	東芝	MOS	20	±6	30	300	150	±100	±6	3	24	15	-4	15	-4	15	0	10		15	10		
3SK37	SONY	"	20	±8	25	230	120	±100	±8	4	20	10	-3	10	-3	10	7.5	9.5		10	5		(200MHz) 0.5
3SK39, 3SK39Z	松下	"	20	±8	24	250	150	±20	±8	1	24	10	-3	10	-3	10	7		18	10	5		
3SK40	日電	"	20	±7	25	250	150	±100	±5	4	25	10	-4	15	-4	15	8	10		15	5		
3SK44	東芝	"	20	±6	45	300	150	±100	±6	3	40	15	-3.3	15	-3.3	15			13	15	10		
3SK45	日立	"	-0.2 +20	±7	35	330	175	±20	±7	4	32	15	-3	15	-2	15	14			15	10		
3SK49, 3SK49Z	松下	"	20	±8	30	350	150	±20	±8	3	30	10	-3	10	-3	10	15			10	5		
(保字・魔品種)3SK32	松下	MOS	20	+8 -10	15	170	125	-0.1	-10	0	5	10	-2.5	10	-2.5	10	5		10	10	5		A

型名	社名	構造	最大定格 (T _a =25°C)						電氣的特性 (T _a =25°C)															
			V _{GS}	V _{DS}	V _{GS0}	I _C	P _d	T _{st}	I _{CSS}	I _{DSS} (mA)		V _p (V)				g _m (mΩ)			g _{os} (mΩ)					
			V _{GS0} V _{GS}	V _{DS} V _{DS}	V _{GS0} V _{GS}	I _D I _D	P _d P _d	T _{st} T _{st}	(nA) (pA)	min	max	V _{DS} (V)	min	max	V _{DS} (V)	I _D (μA)	min	typ	max	V _{DS} (V)	I _D (mA)	typ	max	
2SJ11	東芝	J	20			-10	100	150	1	10	-0.05	-0.9	-10	0.7	5.0	-10	-0.1	0.1		0.6	-10	I _{DSS}		
2SJ12	"	"	20			-10	100	150	0.1	10	-0.09	-0.9	-10	0.7	5.0	-10	-0.1	0.1		0.6	-10	"		
2SJ13	"	"	20			-100	600	150	10	10	-1.0	-12	-10	1.0	6.0	-10	-0.1	1.5		6.0	-10	"		
2SJ15	富士通	"	18		15	-10	200	175	50	9	-1.5 typ	-12		6.0	-10	-10	0.2	1.0	3.0	-12	"			
2SJ16	"	"	18		15	-10	200	175	10	9	-1.5 typ	-12		6.0	-10	-10	0.2	1.0	3.0	-12	"			
2SK13	東芝	J	-12			10	100	150	-0.1	-10	0.45	5.0	10	-0.65	-4.5	10	0.1	0.8		3.2	10	"		
2SK17	"	"	-20			10	100	125	-1	-10	0.3	6.5	10	-0.5	-6.0	10	0.1	0.7	2.0	10	"			
2SK24	三洋	"	-40	40*	-40	10	100	125	-10	-10	0.6	24	10		-6	10	10	1.5		12	10	"		
2SK25	"	"	-18	18*	-18	10	100	125	-100	-10	0.6	24	10		-7.2	10	10		6	10	"			
2SK30	東芝	"	-50			10	100	125	-1	-30	0.3	6.5	10	-0.4	-5.0	10	0.1	1.5		10	"			
2SK39	SONY	"	-20						-0.25	-0.1	0.035	0.564	9					0.09		0.55	9			
3SJ11	日電	MOS	-30	-30	-10	100	100	-100	-10	-10		-0.1μA	-10	-3.0	-6.5	-10	-10		0.8		-10	-10V (V _{GS})		
3SK11	日立	MOS																						
3SK12	"	"																						
3SK13	"	"																						
3SK15	三菱	"	25	+2 -10	10*	100	100	-10	-10		10	6		-9	6	10	0.5	1.0		6	1	0.04		
3SK15A	"	"	25	+2 -10	10*	100	100	-40	-10		10	6		-9	6	10	0.5	1.0		6	1	0.04		
3SK16	"	"	25	+2 -10	10*	100	100	-10	-10		10	6		-9	6	1	0.5	1.0		6	1	0.04		
3SK17	"	"	25	+2 -10	10*	100	100	-1	-10		10	6		-9	6	10	0.5	1.0		6	1	0.04		
3SK18	"	"	15	±10	10*	100	100	-10	-10		5	6		-6	6	10	0.5	1.0		6	1		0.3	
3SK19	"	"	15	±10	10*	100	100	-10	-10		5	6		-6	6	10	0.5	1.0		6	1	0.05	0.1	
3SK23	東芝	J	-15			10	200	150	-100	-10	6	24	10	-1.8		-5.5	1	6		12	10			
3SK24	松下	MOS																						
3SK25	"	"																						
3SK33	日電	"	25	±30	20*	250	150	-1	-10	4	15	10		-4	10	50	4	6		10	5			
3SK38	東芝	"	10	20*	10*	10*	200	125	200	10		50nA	6	0	+3 (V _{GS})	6	50nA	0.35		6				
3SK32	松下																							

電 氣 的 特 性 (Ta=25°C)											其 他	外 形	型 名	
C _{iss} (pF)		I _D (mA)	V _{DS} (V)	C _{oss} (pF)		I _D (mA)	V _{DS} (V)	NF(dB)(200MHz)		V _{DS} (V)				I _D (mA)
typ	max	V _{GS} (V)	V _{GS} (V)	typ	max	V _{GS} (V)	V _{GS} (V)	typ	max	V _{GS} (V)				V _{GS} (V)
5.5		10	15 4	0.02		10	15 4	3.5	5	15 4	10	PG=18dB typ (f=200MHz)	33	3SK35
4.3	6	5	10 5	0.025	0.04	5	10 5	2.6	4	10 5	5	PG=18dB typ (f=200MHz)	34	3SK37
4.5		8*	10 -8	0.01		-8*	10 -8					PG=18dB min (f=200MHz)	39	3SK39, 3SK39Z
5	6.5	5	15 4	0.03	0.05	5	15 4	3	4.5	15 4	5	PG=20dB typ (f=200MHz)	21	3SK40
5.5		10	15 4	0.04		10	15 4	3.5	4	15 4	10	PG=20dB typ (f=200MHz)	33	3SK44
4		10	15 4	0.02	0.03	10	15 4	2.2	3.3	15 4	10	PG=20dB typ (f=200MHz)	17	3SK45
				0.01		-8*	10 -8					PG=19.5dB typ (f=200MHz)	39	3SK49, 3SK49Z
				0.035		-10*	10 -10					PG=25dB typ (f=200MHz)	32	3SK32*

電 氣 的 特 性 (Ta=25°C)											其 他	代 替 品 型 名	外 形	型 名		
C _{iss} (pF)		V _{GS} (V)		C _{oss} (pF)		NF (f=1kHz, R _g =1MΩ)			NF (f=100MHz)							
typ	max	I _D (mA)	V _{DS} (V)	typ	max	V _{GS} (V)	V _{DS} (V)	I _D (mA)	typ	(dB) max					V _{DS} (V)	I _D (mA)
2	4	1	0						1	(dB) max	-10	I _{DSS}			2	2SJ11
2	4	1	0						0.5		-10	*			2	2SJ12
8	12	1	0						入力換算雑音電圧 5μV max (V _{DS} =-10V, I _D =-1mA, Δf=10~100Hz, R _g =1MΩ)						35	2SJ13
6		1	0						4		-6	-0.5			1	2SJ15
6		1	0						2		-6	-0.5			1	2SJ16
2.3	3.5	-10	0						2	10	0.45		NF=5dB max (f=30Hz, R _g =1MΩ, V _{DS} =10V, I _D =0.45mA)	2SK15	2	2SK13
4	6	0	0	1.2	2.0	-10	0	1	10	I _{DSS}				2SK30A	7	2SK17
7.4			10	2.0				1	2.5	10			NF=10dB max (f=30Hz, R _g =1MΩ, V _{DS} =10V)		6	2SK24
				1.1		0*	10						PG=21dB typ (f=100MHz)	2SK41	6	2SK25
8.2		0	0	2.6		-10	0	(f=120Hz, R _g =100kΩ) 0.5 5.0 15	I _{DSS}					2SK30A	7	2SK30
															12	2SK39
5		-10							RON=1kΩ max (V _{DS} =-1V, V _{GS} =-10V) t _{PH(ON)}} =0.4μS typ t _{PH(OFF)}} =0.4μS typ				3SJ11A	23	3SK11	
														3SK20H	26	3SK11
														3SK21H	26	3SK12
														3SK20H	26	3SK13
4		0	0												24	3SK15
4		0	0												24	3SK15A
4		0	0						RON=1kΩ max (V _{DS} =0.1V, V _{GS} =0), ROFF=10MΩ min (V _{DS} =0.1V, V _{GS} =-6V)					24	3SK16	
4		0	0												24	3SK17
0.3		1*	6	0.1		1mA	6	RON=1.2kΩ max (V _{DS} =0.1V, V _{GS} =V _{DS} =0) t _{ON}} =20nS max t _{OFF}} =25nS max					25	3SK18		
0.3		1*	6	0.1		1mA	6			(200MHz)	6	1	PG=20dB typ (f=200MHz)		25	3SK19
		3	0	0	0.4	-10								3SK28	27	3SK23
														3SK39	39	3SK24
														3SK39	39	3SK25
3		5*	10	0.3		5mA	10			3	10	5	PG=15dB min (f=100MHz, unneut realized)		30	3SK33
		4.5	0	0	4.5	0	0	RON=500Ω max (V _{DS} =10mV, V _{GS} =3V), ROFF=100MΩ min (V _{DS} =+10nV, V _{GS} =0)				3SK38A	31	3SK38		

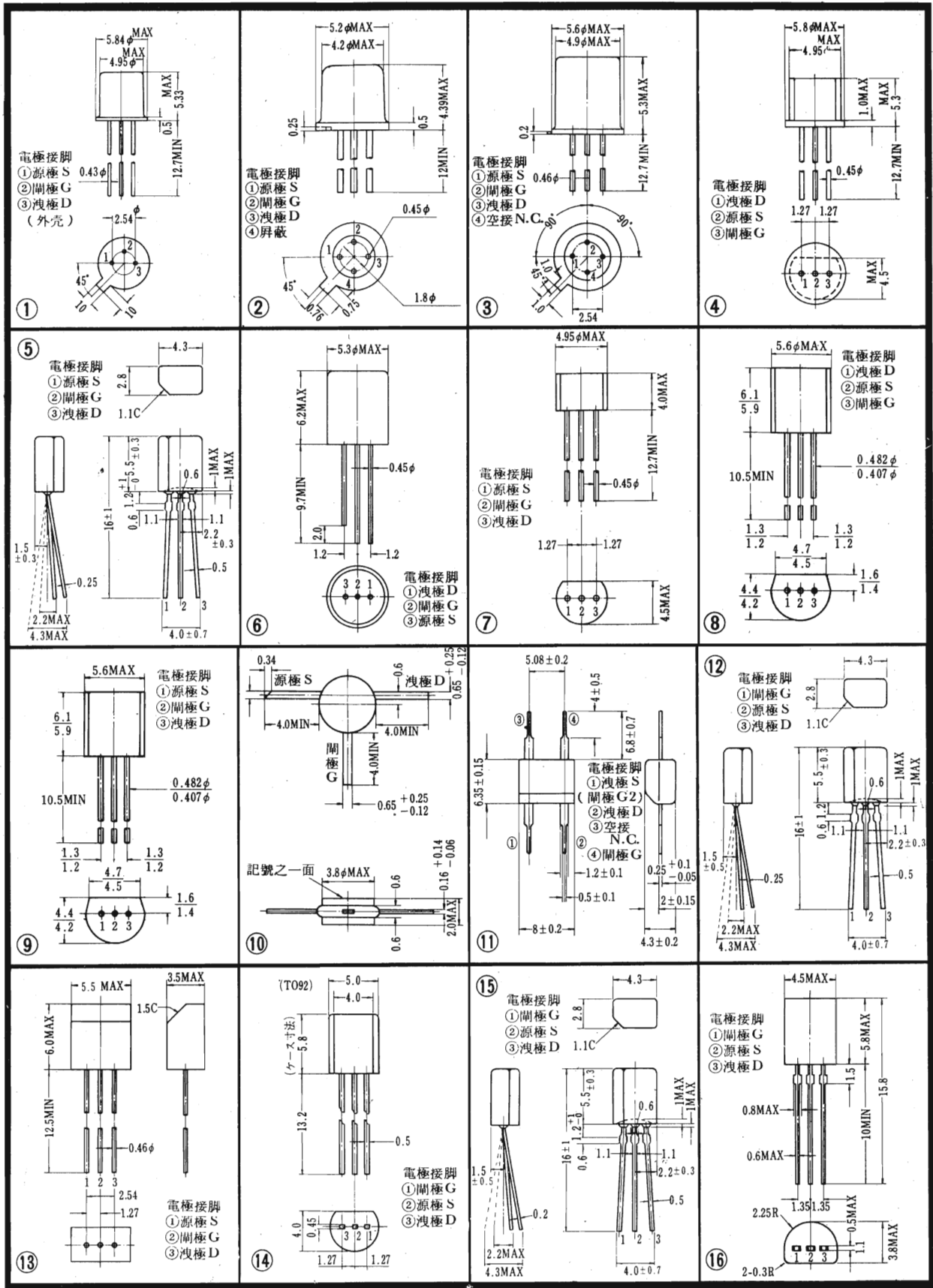

◀◀ 尺寸圖單位 : mm ▶▶

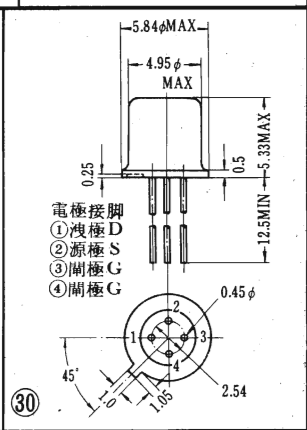
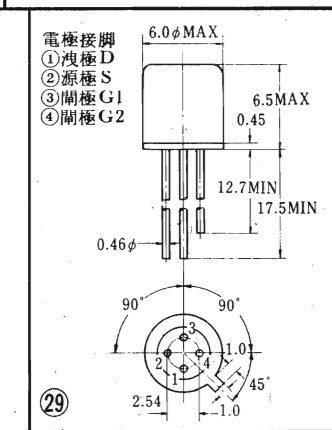
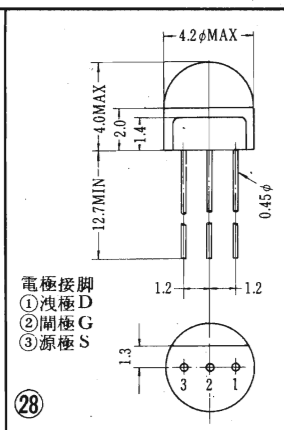
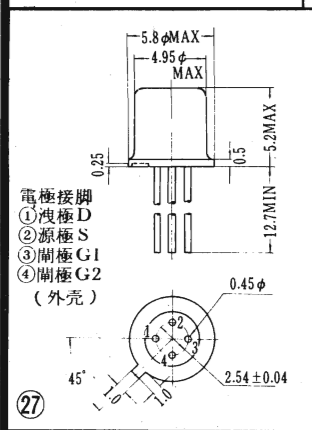
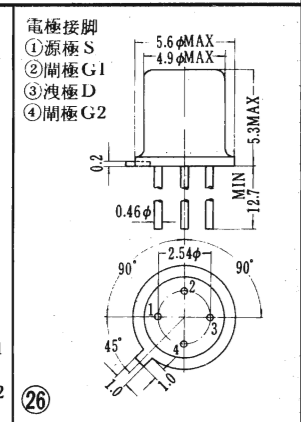
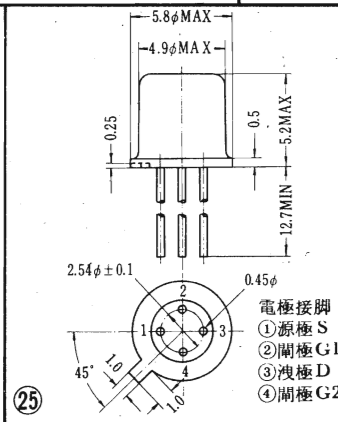
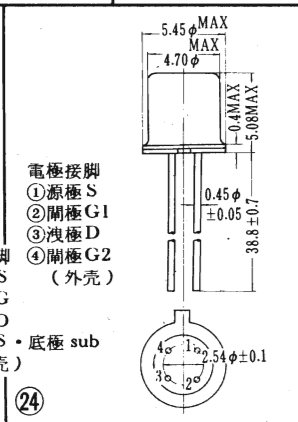
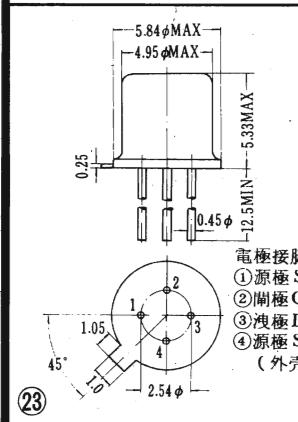
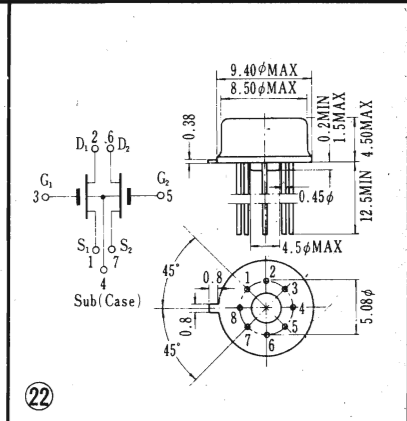
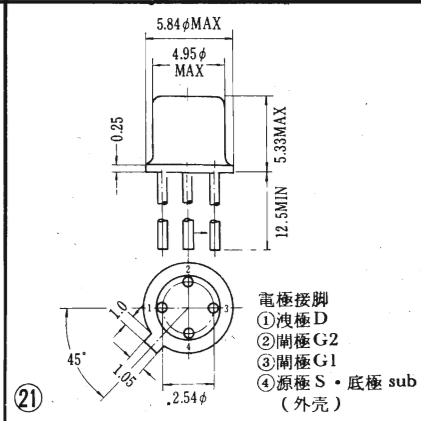
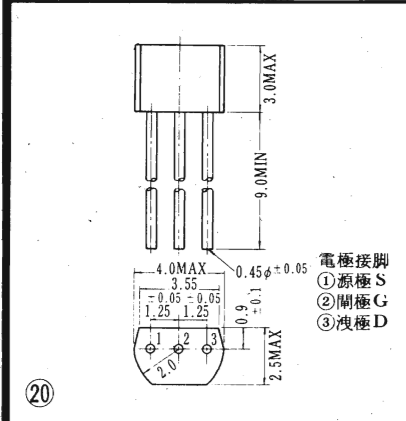
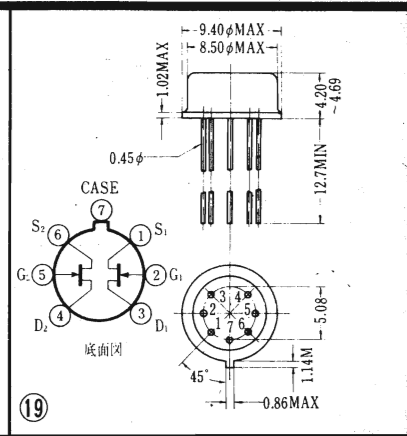
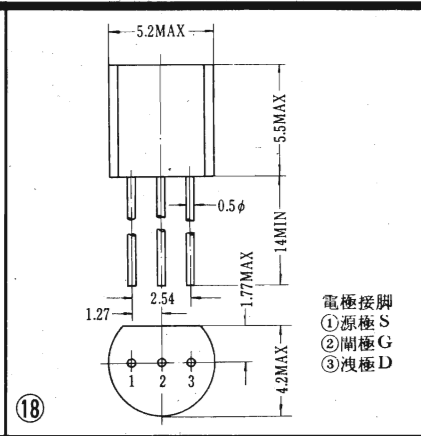
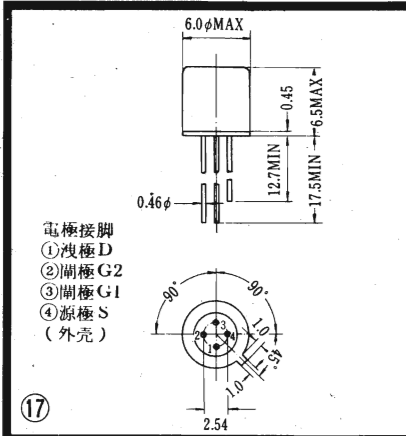

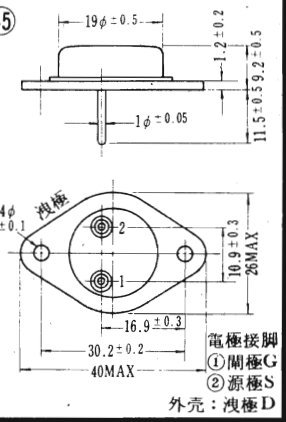
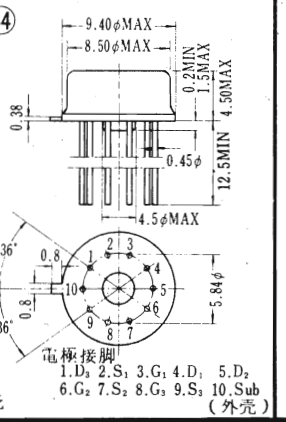
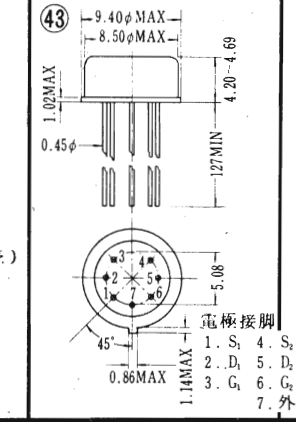
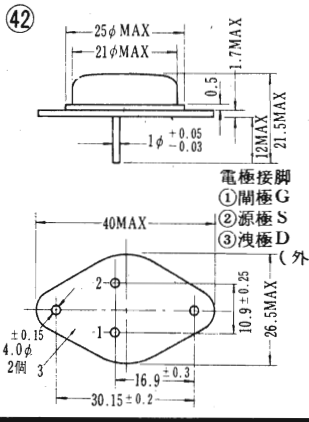
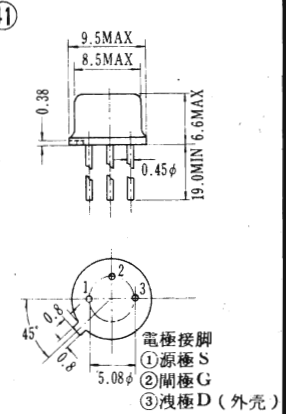
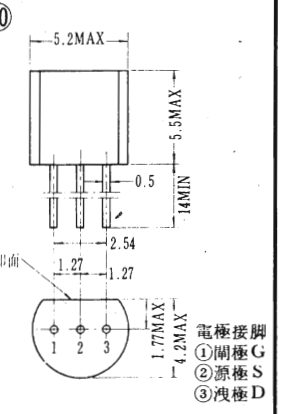
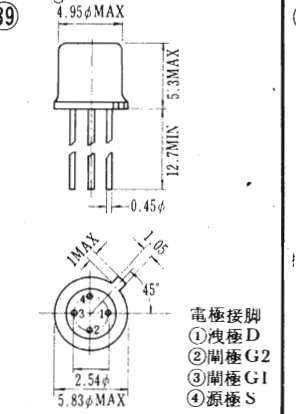
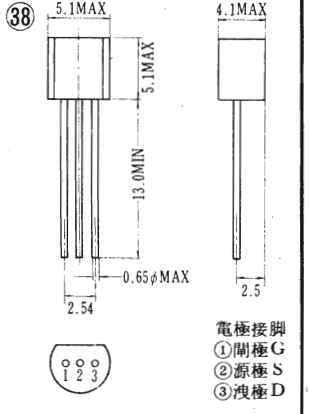
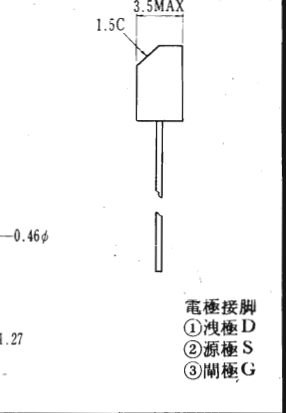
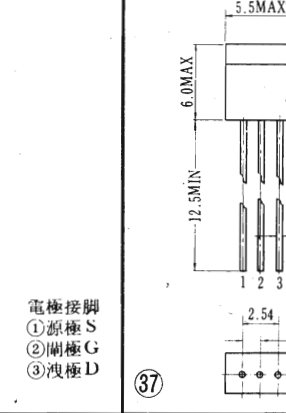
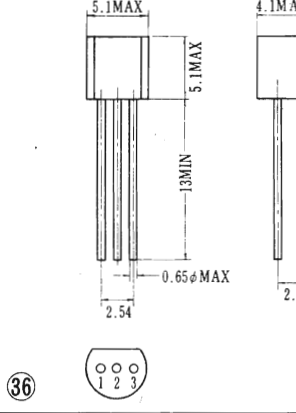
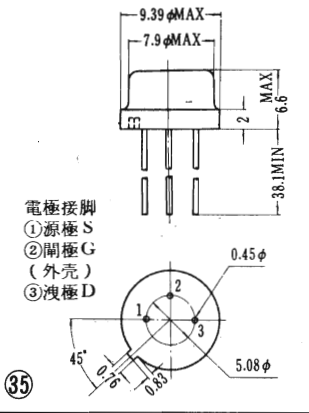
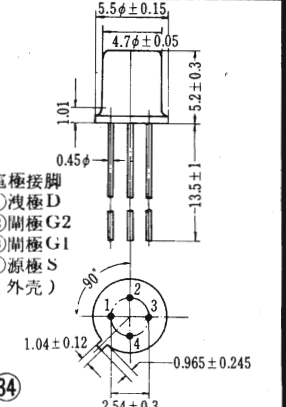
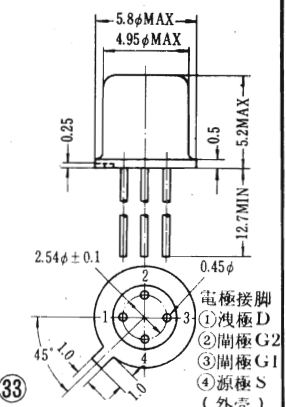
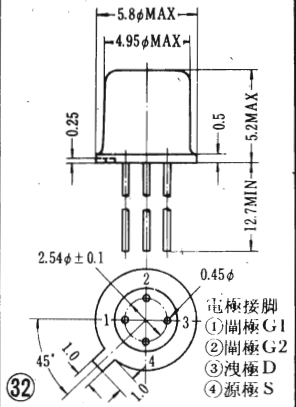
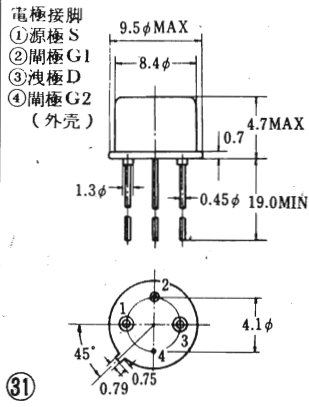



**LISTING OF AMERICAN TYPE
FIELD EFFECT TRANSISTORS**

美式FET特性

型 名	社 名	用 途	構 造	最 大 定 格 (T _a =25°C)						電 氣 的 特 性 (T _a =25°C)							
				V _{GD} (V)	V _{DS} (V)	V _{GS} (V)	I _C [*] I _D (mA)	P _d (mW)	T _j (°C)	I _{gss} (nA) typ	I _{gss} (pA) [*] max	I _{nss} (mA) min	I _{nss} (nA) [*] typ	I _{nss} (nA) [*] max	V _P , V _{th} [*] (V) min	V _P , V _{th} [*] (V) typ	V _P , V _{th} [*] (V) max
2N4360	FC, MOT	低 雜 音	J	20	-20	20	-50*	200	125	0.15	10	-3	-10	-30	0.7	5.5	10
2N3330	MOT, TI, SOL	低 頻 率	"	20		20	-10*	300	200		10	-2		-6			6
2N3909	"	"	"	20	-20	20	-10*	300	200		10	-0.3		-15			8
2N3909A	MOT, TI	"	"	20	-20	20	-10*	300	200		10	-1		-15			8
2N3993	"	CHOPPER SW	"	25	-25	25	-10*	300	200		1.2	-10			4		9.5
2N3993A	"	"	"	25	-25	25	-10*	300	200		1.2	-10			4		9.5
2N3994	"	"	"	25	-25	25	-10*	300	200		1.2	-2			1		5.5
2N3994A	"	"	"	25	-25	25	-10*	300	200		1.2	-2			1		5.5
2N4342	MOT	低 雜 音	"	25	-25	25	-50*	200	125		10	-4		-12	1		5.5
2N4343	"	"	"	25	-25	25	-50*	200	125		10	-10		-30	2		10
2N5460	"	一 般	"	40		40	-10*	310	135		5	-1		-5	0.75		6
2N5461	"	"	"	40		40	-10*	310	135		5	-2		-9	1		7.5
2N5462	"	"	"	40		40	-10*	310	135		5	-4		-16	1.8		9
2N5463	"	"	"	60		60	-10*	310	135		5	-1		-5	0.75		6
2N5464	"	"	"	60		60	-10*	310	135		5	-2		-9	1		7.5
2N5465	"	"	"	60		60	-10*	310	135		5	-4		-16	1.8		9
MPF161	"	"	"	40		40	-20/10	310	135		10	-0.5		-14	0.2		8
2N5018	NS	SW	"	30		30					2	-10					10
2N5019	"	"	"	30		30					2	-5					5
2N5114	NS, SOL	"	"	30		30					0.5	-30		-90			10
2N5115	"	"	"	30		30					0.5	-15		-60			6
2N5116	"	"	"	30		30					0.5	-5		-25			4
P1086E	NS	"	"	30		30					2	-10					10
P1087E	"	"	"	30		30					2	-5					5
PF510	"	"	"	30		30					10	-5					10
PF511	"	"	"	20		20					100	-5					10
UC450	"	"	"	25		25					0.25	-25					10
UC451	"	"	"	25		25					0.25	-3.75		-37.5			6
2N2386	TI, SOL	低 頻 率	"	20			-10*	500	200		10	-0.9		-9			8
2N2386A	TI	"	"	20			-10*	500	200		10	-1		-15			
2N2497	TI, SOL	低 頻 率	J	20			-10*	500	200		10	-1		-3			5
2N2498	"	"	"	20			-10*	500	200		10	-2		-6			6
2N2499	"	"	"	20			-10*	500	200		10	-5		-15			8
2N2500	"	低 雜 音	"	20			-10*	500	200		10	-1		-6			6
2N3329	"	低 頻 率	"			20	-10*	300	200		10	-1		-3			5
2N3331	"	"	"			20	-10*	300	200		10	-5		-15			8
2N3332	"	低 雜 音	"			20	-10*	300	200		10	-1		-6			6
2N3820	TI	一 般	"	20	-20	20	-10*	360	150		20	-0.3		-15			8
2N2607	SOL	"	"			30					3	-0.3		-1.5	1		4
2N2608	"	"	"			30					10	-0.9		-4.5	1		4
2N2609	"	"	"			30					30	-2		-10	1		4
2N2843	"	"	"			30					10	-0.2		-1			1.7
2N2844	"	"	"			30					30	-0.44		-2.2			1.7
2N3380	"	"	"			30					3	-3		-20	4		9.5
UC400	"	低 雜 音	"			30					0.1	-5		-15			6
UC410	"	"	"			30					0.1	-2		-6			4
UC420	"	"	"			30					0.1	-0.5		-2.3			2.5
UC805	"	一 般	"			25					1	-0.3		-25			8
UC814	"	"	"			25					2	-0.3		-15			8
UC851	"	"	"			20					4	-0.9		-9			6
UC854	"	"	"			25					15	-0.2					6
UC855	"	"	"			25					25	-0.44					6
MFE 4007	MOT	"	"	40	-40	40	-20/10*	300	175		2	-0.5		-1			-3
MFE 4008	"	"	"	40	-40	40	-20/10*	300	175		2	-0.8		-1.6			-3
MFE 4009	"	"	"	40	-40	40	-20/10*	300	175		2	-1.5		-3			-6
MFE 4010	"	"	"	40	-40	40	-20/10*	300	175		2	-2.5		-5			-6
MFE 4011	"	"	"	40	-40	40	-20/10*	300	175		2	-4		-8			-8
MFE 4012	"	"	"	40	-40	40	-20/10*	300	175		2	-7		-14			-8
2N5265	"	"	"	60	-60	60	-20/10*	300	175		2	-0.5		-1			3
2N5266	"	"	"	60	-60	60	-20/10*	300	175		2	-0.8		-1.6			3

電 氣 的 特 性 (Ta = 25°C)

g _m (mS)		g _{os} (mS)		C _{is} (pF)		C _{rs} (pF)		C _{os} (pF)		R _{DS-ON} (Ω)		NF(dB)		PG(dB)		NF(dB)		外 形	型 名		
min	typ	max	typ	max	typ	max	typ	max	typ	max	typ	max	typ	max	min	typ	f(MHz)			typ	max
2	4	8	0.035	0.1	15	20	3	5			350	700	0.1	1.5	100	1 M				TO-92	2N4360
1.5		3		0.04		20					800		3	1k	1 M					TO-72	2N3330
1		5		0.1		32					16									"	2N3909
2.2		5		0.1		9					3									"	2N3909A
6		12				16	4.5				150									"	2N3993
7		12				12					3									"	2N3993A
4		10				16					5									"	2N3994
5		10				12	3.5				300									"	2N3994A
2		6		0.075		20					5		1.5	100	1 M					TO-92	2N4342
4		8		0.1		20					5		1.5	100	1 M					"	2N4343
1		4		0.05	5	7	1	2				1	2.5	100	1 M					"	2N5460
1.5		5		0.05	5	7	1	2				1	2.5	100	1 M					"	2N5461
2		6		0.05	5	7	1	2				1	2.5	100	1 M					"	2N5462
1		4		0.05	5	7	1	2				1	2.5	100	1 M					"	2N5463
1.5		5		0.05	5	7	1	2				1	2.5	100	1 M					"	2N5464
2		6		0.05	5	7	1	2				1	2.5	100	1 M					"	2N5465
0.8		6		0.075		7		2					2.5	1k	1 M					"	MPF161
						45		10			75		t _{ON} = 20nS max				t _{OFF} = 30nS max			TO-18P	2N5018
						45		10			150		"	75			"	40		"	2N5019
						25		7			75		"	16			"	21		"	2N5114
						25		7			100		"	32			"	42		"	2N5115
						25		7			150		"	45			"	75		"	2N5116
						45		10			75		"	20			"	30		TO-106 E _{poxy}	P1086E
						45		10			150		"	75			"	40		"	P1087E
											200									TO-18P	PF510
											200									"	PF511
						25					60									"	UC450
						25					150									"	UC451
1						50							2							TO-5	2N2386
2.2		5				10														"	2N2386A
1		2		0.02		32					1000		3	1k	1 M					TO-5	2N2497
1.5		3		0.04		32					800		3	"	"					"	2N2498
2		4		0.1		32					600		4	"	"					"	2N2499
1		2.2		0.02		32							1	"	"					"	2N2500
1		2		0.02		20					1000		3	"	"					TO-72	2N3329
2		4		0.1		20					600		4	"	"					"	2N3331
1		2.2		0.02		20							1	"	"					"	2N3332
0.8		5		0.2		32		16												TO-92	2N3820
0.33						10							3							TO-18	2N2607
1						17							3							"	2N2608
2.5						25							3							"	2N2609
0.54						17							3							"	2N2843
1.8						30							3							"	2N2844
1.5		3				5														TO-72	2N3380
3						8														"	UC400
2.25						8							0.5							"	UC410
1.5						8							0.5							"	UC420
1		10				12							0.5							"	UC805
0.8		5				16		8					2							"	UC814
1						17							2							TO-18	UC851
0.54						17														"	UC854
1.4						25														"	UC855
0.9		2.7		0.075		7		2					2.5	100	1 M					TO-72	MFE4007
1		3		0.075		7		2					2.5	100	"					"	MFE4008
1.5		3.5		0.075		7		2					2.5	100	"					"	MFE4009
2		4		0.075		7		2					2.5	100	"					"	MFE4010
2.2		4.5		0.075		7		2					2.5	100	"					"	MFE4011
2.5		5		0.075		7		2					2.5	100	"					"	MFE4012
0.9		2.7		0.075		7		2					2.5	100	"					"	2N5265
1		3		0.075		7		2					2.5	100	"					"	2N5266

型名	社名	用途	構造	最大定格 (Ta=25°C)						電気的特性 (Ta=25°C)						
				V _{GD} (V)	V _{DS} (V)	V _{GS} (V)	I _C [*] I _D (mA)	P _a (mW)	T _j (°C)	I _{CS} (nA) typ	I _{CS} (pA) [*] max	I _{DSS} (mA) [*] min typ max	V _P , V _{th} [*] (V) min typ max			
2N5434	NS	SW, CHOPPER	J			-25						-0.2	30			-4
2N5555	NS, MOT	"	"	-25	25	-25	10 [*]	310	175			-1	15			-10
2N5638	"	"	"	-30	30	-30	10 [*]	310	135			-1	50			-12
2N5639	"	"	"	-30	30	-30	10 [*]	310	135			-1	25			-8
2N5640	"	"	"	-30	30	-30	10 [*]	310	135			-1	5			-6
2N5653	"	"	"	-30		-30	10 [*]	310	150			-1	40			-12
2N5654	"	"	"	-30		-30	10 [*]	310	150			-1	15			-8
KE4091	NS	"	"			-40						-1	30			-10
KE4092	"	"	"			-40						-1	15			-7
KE4093	"	"	"			-40						-1	8			-5
KE4391	"	"	"			-40						-1	50	150		-10
KE4392	"	"	"			-40						-1	25	75		-5
KE4393	"	"	"			-40						-1	5	30		-3
KE4856	"	"	"			-40						-1	50			-10
KE4857	"	"	"			-40						-1	20	100		-6
KE4858	"	"	"			-40						-1	8	80		-4
KE4859	"	"	"			-30						-1	50			-10
KE4860	"	"	"			-30						-1	20	100		-6
KE4861	"	"	"			-30						-1	8	80		-4
NF510	"	"	"			-30							5			-10
NF511	"	"	"			-20							5			-10
NF580	"	"	"			-25						-1				-12
NF581	"	"	"			-25						-1				-10
NF582	"	"	"			-25						-1				-6
NF583	"	"	"			-25						-1				-4
NF584	"	"	"			-15						-50				-10
NF585	"	"	"			-15						-50				-6
NF4445	"	"	"			-25						-3	150			-10
NF4446	"	"	"			-25						-3	100			-10
NF4447	"	"	"			-20						-3	150			-10
NF4448	NS	SW·CHOPPER	J			-20						-3	100			-10
NF5555	"	"	"			-25						-10	15			-10
NF5638	"	"	"			-30						-1	50			-12
NF5639	"	"	"			-30						-1	25			-8
NF5640	"	"	"			-30						-1	5			-6
NF5653	"	"	"			-30						-1	40			-12
NF5654	"	"	"			-30						-1	15			-8
TI541	"	"	"			-30						-0.5	50			-10
TIS73	NS, TI	"	"	-30	30	-30	50 [*]	360	150			-2	50		-4	-10
TIS74	"	"	"	-30	30	-30	50 [*]	360	150			-2	20	100	-2	-6
TIS75	"	"	"	-30	30	-30	50 [*]	360	150			-2	8	80	-0.8	-4
UI897E	NS	"	"			-40						-1	30			-10
UI898E	"	"	"			-40						-1	15			-7
UI899E	"	"	"			-40						-1	8			-5
UC250	NS, SOL	"	"			-30						-1	50	150		-10
UC251	"	"	"			-30						-1	7.5	75		-6
2N3821	富士通	一般	"	-50	50	-50	10	300	175			-0.1	0.5	2.5		-4
2N3822	"	"	"	-50	50	-50	10	300	175			-0.1	2	10		-6
2N3823	"	VHF, RF	"	-30	30	-30	10 [*]	300	175			-0.5	4	20		-8
2N4223	NS, MOT, SOL	"	"	-30	30	-30	20	300	175			-0.25	3	18		-8
2N4224	"	VHF, UHF, RF	"	-30	30	-30	20	300	175			-0.5	2	20		-8
2N5078	NS	VHF, RF	"	-30								-0.25	4	25		-8
2N5103	NS, SOL	"	"			-25						-0.1	1	8		-4
2N5104	"	"	"			-25						-0.1	2	6		-4
2N5105	"	"	"			-25						-0.1	5	15		-4
2N5245	NS, TI	VHF, UHF, RF	"	-30		-30	50 [*]	360	150			-1	5	15	-1	-6
2N5246	"	"	"	-30		-30	50 [*]	360	150			-1	1.5	7	-0.5	-4
2N5247	"	"	"	-30		-30	50 [*]	360	150			-1	8	24	-1.5	-8
2N5248	"	VHF, RF	"	-30		-30	10 [*]	360	150			-5	4	20	-1	-8
2N5484	NS, MOT	"	"	-25		-25	10 [*]	310	150			-1	1	5		-3

電 氣 的 特 性 (Ta=25°C)															外 形	型 名							
gm(mS)			gos(mS)			Cis(pF)		Crs(pF)		Cos(pF)		RDS(ON)(Ω)		NF(dB)			PG(dB)		NF(dB)				
min	typ	max	typ	max	typ	max	typ	max	typ	max	typ	max	typ	max			f(Hz)	Rg(Ω)	min	typ	f(MHz)	typ	max
					30	15					10			ton= 5					tOFF=36			TO-52	2N5434
					5	1.2					150			" 10					" 25			TO-92 Epoxy	2N5555
					10	4					30			" 9					" 15			"	2N5638
					10	4					60			" 14					" 30			"	2N5639
					10	4					100			" 18					" 45			"	2N5640
					10	3.5					50			" 9					" 15			"	2N5653
					10	3.5					100			" 14					" 30			"	2N5654
					16	5					30			" 25					" 40			TO-106 Epoxy	KE4091
					16	5					50			" 35					" 60			"	KE4092
					16	5					80			" 60					" 80			"	KE4093
					10	3.5					30			" 20					" 35			"	KE4391
					10	3.5					60			" 20					" 35			"	KE4392
					10	3.5					100			" 20					" 80			"	KE4393
					18	8					25			" 9					" 25			"	KE4856
					18	8					40			" 10					" 50			"	KE4857
					18	8					60			" 20					" 100			"	KE4858
					18	8					25			" 9					" 25			"	KE4859
					18	8					40			" 10					" 50			"	KE4860
					18	8					60			" 20					" 100			"	KE4861
											100											TO-18	NF510
											100											"	NF511
					25	13					5			" 5					" 25			TO-52	NF580
					25	13					6			" 5					" 25			"	NF581
					25	13					10			" 5					" 25			"	NF582
					25	13					20			" 10					" 25			"	NF583
					25	13					10			"								"	NF584
					25	13					20			"								"	NF585
					50	25					5			" 35					" 35			"	NF4445
					50	25					10			" 35					" 35			"	NF4446
					50	25					6			" 35					" 35			"	NF4447
					50	25					12			ton=35					tOFF=35			TO-52	NF4448
					5	1.2					150			" 10					" 25			TO-72	NF5555
					10	4					30			" 9					" 15			TO-18	NF5638
					10	4					60			" 14					" 30			"	NF5639
					10	4					100			" 18					" 45			"	NF5640
					10	3.5					50			" 9					" 15			"	NF5653
					10	3.5					100			" 14					" 30			"	NF5654
					18	8					25											"	TIXS41
					18	8					25			ton 9					tOFF 25			TO-106 Epoxy	TIS73
					18	8					40			" 10					50			"	TIS74
					18	8					60			ton=20nS max					tOFF=100nS max			"	TIS75
					16						30			" 25					" 40			"	U1897E
					16						50			" 35					" 60			"	U1898E
					16						80			" 60					" 80			"	U1899E
					25						30											TO-18	UC250
					25						75											"	UC251
1.5	4.5	0.01	6	3										5	10	1 M						TO-72	2N3821
3	6.5	0.02	6	3										5	10	1 M						"	2N3822
3.5	6.5	0.035	6	2														100		2.5		"	2N3823
3	7	0.2	6	2													10		200		5	"	2N4223
2	7.5	0.2	6	2													12		400			"	2N4224
4			6	2																		"	2N5078
2			5	1																		"	2N5103
3.5			5	1																		"	2N5104
5			5	1																		"	2N5105
4.5	7.5	0.05	4.5	1													10		400		4	TO-106 Epoxy	2N5245
3	6	0.05	4.5	1																		"	2N5246
4.5	8	0.07	4.5	1																		"	2N5247
3.5	6.5	0.05	6	2													(max)					TO-92 Epoxy	2N5248
3	6	0.05	5	1		2								2.5	1 k	1 M	16	25	100		3	"	2N5484

型名	社名	用途	構造	最大定格 (Ta=25°C)						電気的特性 (Ta=25°C)					
				V _{GD} (V)	V _{DS} (V)	V _{GS} (V)	I _C [*] I _D (mA)	P _d (mW)	T _j (°C)	I _{GSS} (nA) typ	I _{GSS} (pA) max	I _{BSS} (mA) min typ	I _{BSS} (nA) max	V _P , V _{th} [*] (V) min typ max	
2N5485	NS, MOT	VHF,UHF,RF	J	-25		-25	10 30	310	150		-1	4	10		-4
2N5486	"	"	"	-25		-25	10 30	310	150		-1	8	20		-6
2N5668	"	VHF, RF	"	-25	25	-25	10 20	310	150		-2	1	5		-4
2N5669	"	"	"	-25	25	-25	10 20	310	150		-2	4	10		-6
2N5670	"	"	"	-25	25	-25	10 20	310	150		-2	8	20		-8
KE4416	NS, SOL	VHF,UHF,RF	"			-30					-1	5	15		-6
MPF 102	NS, MOT	VHF, RF	"	-25	25	-25	10	310	125		-2	2	20		-8
MPF 106	NS	VHF,UHF,RF	"			-25					-1	4	10		-4
MPF 107	"	"	"			-25					-1	8	20		-6
MPF 108	NS, MOT	VHF, RF	"	-25	25	-25	10	310	135		-1	1.5	24	-0.5	-8
MPF 112	"	"	"	-25	25	-20	10	200	125		-100	1	25	-0.5	-10
NF500	NS	"	"			-25					-10	1	30		-8
NF501	"	"	"			-15					-50	1	30		-8
NF506	"	"	"			-25					-1	4	15		-5
NF5485	"	VHF,UHF,RF	"			-25					-1	4	10		-4
NF5486	"	"	"			-25					-1	8	20		-6
TIS34	"	VHF, RF	"			-30					-5	4	20		-8
TIS88	"	VHF,UHF,RF	"			-30					-1	5	15		-6
U1837E	"	VHF, RF	"			-30					-1	4	25		-8
U1994E	"	VHF,UHF,RF	"			-30					-1	5	15		-6
UC734	NS, SOL	VHF, RF	"			-30					-5	4	20		-8
UC734E	"	"	"			-30					-5	4	20		-8
2N3458	"	低雑音	"	-50							-0.25	3	15		-8
2N3459	"	"	"	-50							-0.25	0.2	4		-4
2N3460	"	"	"	-50							-0.25	0.2	1		-2
2N3684	"	"	"			-50					-0.1	2.5	7.5		-5
2N3685	"	"	"			-50					-0.1	1	3		-3.5
2N3686	"	"	"			-50					-0.1	0.4	1.2		-2
2N3687	"	"	"			-50					-0.1	0.1	0.5		-1.2
2N4338	"	"	"			-50					-0.1	0.2	0.6		-1
2N4339	NS, SOL	低雑音	J			-50					-0.1	0.5	1.5		-1.8
2N4340	"	"	"			-50					-0.1	1.2	3.6		-3
2N4341	"	"	"			-50					-0.1	3	9		-6
KE 3684	NS	"	"			-50					-1	2.5	7.5		-5
KE3685	"	"	"			-50					-1	1	3		-3.5
KE3686	"	"	"			-50					-1	0.4	1.2		-2
KE3687	"	"	"			-50					-1	0.1	0.5		-1.2
2N3069	NS, SOL	一般	"	-50							-1	2	10		-10
2N3070	"	"	"	-50							-1	0.5	2.5		-5
2N3071	"	"	"	-50							-1	0.1	0.6		-2.5
2N3365	"	"	"	-40							-5	0.8	4		-12
2N3366	NS	"	"	-40							-5	0.2	1		-7
2N3367	"	"	"	-40							-5		0.25		-2.5
2N3368	NS, SOL	"	"	-40							-5	2	12		-12
2N3369	"	"	"	-40							-5	0.5	2.5		-7
2N3370	"	"	"	-40							-5	0.1	0.6		-3.5
2N3436	"	"	"	-50							-0.5	3	15		-10
2N3437	"	"	"	-50							-0.5	0.8	4		-5
2N3438	"	"	"	-50							-0.5	0.2	1		-2.5
2N3819	NS, TI	"	"	-25	25	-25	10	360	150		-2	2	20		-8
2N3967	NS	"	"			-30					-0.1	2.5	10		-5
2N3967A	"	"	"			-30					-0.1	2.5	10		-5
2N3968	"	"	"			-30					-0.1	1	5		-3
2N3968A	"	"	"			-30					-0.1	1	5		-3
2N3969	"	"	"			-30					-0.1	0.4	2		-1.7
2N4969A	"	"	"			-30					-0.1	0.4	2		-1.7
2N4220	NS,MOT,SOL	"	"	-30	30	-30	15	300	175		-0.1	0.5	3		-4
2N4220A	"	"	"	-30	30	-30	15	300	175		-0.1	0.5	3		-4
2N4221	"	"	"	-30	30	-30	15	300	175		-0.1	2	6		-6
2N4221A	"	"	"	-30	30	-30	15	300	175		-0.1	2	6		-6

電 氣 的 特 性 (T _a = 25°C)															外 形	型 名							
g _m (mS)		g _{os} (mS)		C _{is} (pF)		C _{rs} (pF)		C _{os} (pF)		R _{DS(ON)} (Ω)		NF(dB)		PG(dB)			NF(dB)						
min	typ	max	typ	max	typ	max	typ	max	typ	max	typ	max	f(Hz)	R _g (Ω)	min	typ	f(MHz)	typ	max				
3.5		7		0.06		5		1		2			2.5	1 k	1 M	10	(max) 20	400		4	TO-92 Epoxy	2N5485	
4		8		0.075		5		1		2			2.5	1 k	1 M	10	(max) 20	400		4	"	2N5486	
1.5		6.5		0.02	4.7	7	1	3	1.4	4						16		100		2.5	"	2N5668	
2		6.5		0.05	4.7	7	1	3	1.4	4						16		100		2.5	"	2N5669	
3		7.5		0.075	4.7	7	1	3	1.4	4						16		100		2.5	"	2N5670	
4	(400MHz)					4		0.8								10		400		4	TO-106 Epoxy	KE4416	
2		7.5		0.2		7		3														TO-92 Epoxy	MPF102
						5		2								10		400	(100MHz) 2			"	MPF106
						5		2								10		400	(100MHz) 2			"	MPF107
2		7.5		0.2		6.5		2.5					2.5	1 k	1 M			100		3		"	MPF108
1		7.5			8		3															"	MPF112
																						TO-72	NF500
																						"	NF501
						4		1								18		100		2		"	NF506
3	(400MHz)					5		1								10		400		4		"	NF5485
3.5	(")					5		1								10		400		4		"	NF5486
3	(200MHz)					6		2														TO-106 Epoxy	TIS34
4	(400MHz)					4.5		1								10		400		4		"	TIS88
4	(200MHz)					6		2														"	UI837E
4	(400MHz)					4		1								10		400		4		"	UI994E
3	(200MHz)					4		0.8														TO-72	UC734
3	(")					4		1														TO-106 Epoxy	UC734E
2.5		10				18							1	1 k	1 M							TO-18	2N3548
1.5		6				18							1	1 k	1 M							"	2N3549
0.8		4.5				18							1	1 k	1 M							"	2N3460
2		3				4		1.2					0.5	100	10M							TO-72	2N3684
1.5		2.5				4		1.2					0.5	100	10M							"	2N3685
1		2				4		1.2					0.5	100	10M							"	2N3686
0.5		1.5				4		1.2					0.5	100	10M							"	2N3687
0.6		1.8				6		2					1	1 k	1 M							TO-18	2N4338
0.8		2.4				6		2					1	1 k	1 M							TO-18	2N4339
1.3		3				6		2					1	1 k	1 M							"	2N4340
2		4				6		2					1	1 k	1 M							"	2N4341
2		3				4		1.2					0.5	100	10M							TO-106 Epoxy	KE3684
1.5		2.5				4		1.2					0.5	100	10M							"	KE3685
1		2				4		1.2					0.5	100	10M							"	KE3686
0.5		1.5				4		1.2					0.5	100	10M							"	KE3687
1		2.5				15							4									TO-18	2N3069
0.75		2.5				15							4									"	2N3070
0.5		2.5				15							4									"	2N3071
0.4		2				15																"	2N3365
0.25		1				15																"	2N3366
0.1		1				15																"	2N3367
1		4				20																"	2N3368
0.6		2.5				20																"	2N3369
0.3		2.5				20																"	2N3370
2.5		10				18							2									"	2N3436
1.5		6				18							2									"	2N3437
0.8		4.5				18							2									"	2N3438
2		6.5		0.05		8		4														TO-106 Epoxy	2N3819
1.6		2.4				5		1.3					1.5									TO-72	2N3967
1.6		2.4				5		1.3					1.5									"	2N3967A
1.4		2				5		1.3					1.5									"	2N3968
1.4		2				5		1.3					1.5									"	2N3968A
0.95		1.45				5		1.3					1.5									"	2N3969
0.95		1.45				5		1.3					1.5									"	2N3969A
1		4		0.01	4.5	6	1.2	2	1.5				500									"	2N4220
1		4		0.01	4.5	6	1.2	2	1.5				500		2.5	100	1 M					"	2N4220A
2		5		0.02	4.5	6	1.2	2	1.5				400									"	2N4221
2		5		0.02	4.5	6	1.2	2	1.5				400		2.5	100	1 M					"	2N4221A

型名	社名	用途	構造	最大定格 (Ta=25°C)						電氣的特性 (Ta=25°C)							
				V _{GD} (V)	V _{DS} (V)	V _{GS} (V)	I _C * I _D * (mA)	P _d (mW)	T _j (°C)	I _{GSS} (nA) typ	I _{GSS} (pA)* max	I _{DSS} (mA)* min typ	I _{DSS} (nA)* max	V _P , V _{th} * (V)			
2N4222	NS, MOT, SOL	一般	J	-30	30	-30	15	300	175		-0.1	5	15		-8		
2N4222A	"	"	"	-30	30	-30	15	300	175		-0.1	5	15		-8		
2N4302	NS	"	"	-30							-1	0.5	5		-4		
2N4303	"	"	"	-30							-1	4	10		-6		
2N4304	"	"	"	-30							-1	0.5	15		-10		
2N5163	"	"	"			-25					-10	1	40		-8		
2N5358	NS, MOT	"	"	-40		-40	10*	300	175		-0.1	0.5	1	-0.5	-3		
2N5359	"	"	"	-40		-40	10*	300	175		-0.1	0.8	1.6	-0.8	-4		
2N5360	"	"	"	-40		-40	10*	300	175		-0.1	1.5	3	-0.8	-4		
2N5361	"	"	"	-40		-40	10*	300	175		-0.1	2.5	5	-1	-6		
2N5362	"	"	"	-40		-40	10*	300	175		-0.1	4	8	-2	-7		
2N5363	"	"	"	-40		-40	10*	300	175		-0.1	7	14	-2.5	-8		
2N5364	"	"	"	-40		-40	10*	300	175		-0.1	9	18	-2.5	-8		
2N5457	"	"	"	-25	25	-25	10*	310	135		-1	1	3	5	-0.5	-6	
2N5458	"	"	"	-25	25	-25	10*	310	135		-1	2	6	9	-1	-7	
2N5459	"	"	"	-25	25	-25	10*	310	135		-1	4	9	16	-2	-8	
E100	NS	"	"			-30					-0.5	0.2	20		-10		
E101	"	"	"			-30					-0.5	0.2	1		-1.5		
E102	"	"	"			-30					-0.5	0.9	4.5		-4		
E103	"	"	"			-30					-0.5	4	20		-10		
MPF103	"	"	"			-25					-1	1	5		-6		
MPF104	"	"	"			-25					-1	2	9		-7		
MPF105	"	"	"			-25					-1	4	16		-8		
MPF109	NS, MOT	"	"	-25	25	-25	10*	310	135		-1	0.5	24	-0.2	-8		
MPF110	NS	"	"			-20					-100	0.5	20				
MPF111	NS, MOT	"	"	-20	20	-20	10*	200	125	0.1	-100	0.5	8	20	-0.5	-4	-10
NF520	NS	"	"			-30					-1	1	10		-8		
NF521	"	"	"			-30					-1	0.1	2		-8		
NF522	"	"	"			-20					-10	1	10		-8		
NF523	"	"	"			-20					-10	0.1	2		-8		
NF530	NS	一般	J			-30					-1	1	10		-8		
NF531	"	"	"			-30					-1	0.1	2		-8		
NF532	"	"	"			-20					-10	1	10		-8		
NF533	"	"	"			-20					-10	0.1	2		-8		
NF5457	"	"	"			-25					-1	1	5		-6		
NF5458	"	"	"			-25					-1	2	9		-7		
NF5459	"	"	"			-25					-1	4	16		-8		
KE4220	"	"	"			-30					-1	0.5	3		-4		
KE4221	"	"	"			-30					-1	2	6		-6		
KE4222	"	"	"			-30					-1	5	15		-8		
TIS58	NS, TI	"	"	-25	25	-25	10*	360	150		-4	2.5	8	-0.5	-5		
UC714	NS, SOL	"	"			-30					-1	2	20		-8		
MFE2000	MOT	VHF, UHF, RF	"	-25	25	-25	30	300	175		-0.1	4	10				
MFE2001	"	"	"	-25	25	-25	30	300	175		-0.1	8	20				
MFE2004	"	CHOPPER	"	-30	30	-30	10*	(T _C =25°C) 1.8W	175		-0.2	8			-12		
MFE2005	"	"	"	-30	30	-30	10*	"	175		-0.2	15			-12		
MFE2006	"	"	"	-30	30	-30	10*	"	175		-0.2	30			-12		
MFE2007	"	"	"	-25	25	-25	50*	"	175		-2	8		-0.5	-10		
MFE2008	"	"	"	-25	25	-25	50*	"	175		-2	20		-1	-10		
MFE2009	"	"	"	-25	25	-25	50*	"	175		-2	50		-3	-10		
MFE2010	"	"	"	-25	25	-25	50*	"	175		-3	15		-0.5	-10		
MFE2011	"	"	"	-25	25	-25	50*	"	175		-3	40		-1	-10		
MFE2012	"	"	"	-25	25	-25	50*	"	175		-3	100		-3	-10		
2N5556	"	低雑音	"	-30	30	-30	10*	300	175		-0.1	0.5	2.5	-0.2	-4		
2N5557	"	"	"	-30	30	-30	10*	300	175		-0.1	2	5	-0.8	-5		
2N5558	"	"	"	-30	30	-30	10*	300	175		-0.1	4	10	-1.5	-6		
2N5716	"	低頻	"	-40	40	-40	10*	200	125		-1	0.05	0.25	-0.2	-3		
2N5717	"	"	"	-40	40	-40	10*	200	125		-1	0.2	1	-0.5	-5		
2N5718	"	"	"	-40	40	-40	10*	200	125		-1	0.8	4	-1	-8		
MFE2093	"	一般	"	-50	50	-50	3	300	175		-0.1	0.1	0.35	0.7	-1.5	-2.5	

電 氣 的 特 性 (T _a = 25°C)															外 形	型 名								
g _m (mS)			g _{os} (mS)			C _{is} (pF)		C _{rs} (pF)		C _{os} (pF)		R _{DS(ON)} (Ω)		NF (dB)			PG (dB)		NF (dB)					
min	typ	max	typ	max	typ	max	typ	max	typ	max	typ	max	typ	max	f (Hz)	R _g (Ω)	min	typ	f (MHz)	typ	max			
2.5		6	0.04	4.5	6	1.2	2	1.5	300														TO-72	2N4222
2.5		6	0.04	4.5	6	1.2	2	1.5	300					2.5	100	1 M							"	2N4222A
1					6		3							2									TO-106 Epoxy	2N4302
2					6		3							2									"	2N4303
1					6		3							3									"	2N4304
2		9			20		5																"	2N5163
1		3	0.01		6		2							2.5	100	1 M							TO-72	2N5358
1.2		3.6	0.01		6		2							2.5	100	1 M							"	2N5359
1.4		4.2	0.02		6		2							2.5	100	1 M							"	2N5360
1.5		4.5	0.02		6		2							2.5	100	1 M							"	2N5361
2		5.5	0.04		6		2							2.5	100	1 M							"	2N5362
2.5		6	0.04		6		2							2.5	100	1 M							"	2N5363
2.7		6.5	0.06		6		2							2.5	100	1 M							"	2N5364
1	3	5	0.01	0.05	4.5	7	1.5	3															TO-92 Epoxy	2N5457
1.5	4	5.5	0.01	0.05	4.5	7	1.5	3															"	2N5458
2	4.5	6	0.01	0.05	4.5	7	1.5	3															"	2N5459
0.5					8		3																TO-106 Epoxy	E100
0.5					8		3																"	E101
1					8		3																"	E102
1.5					8		3																"	E103
1					7		3																TO-92 Epoxy	MPF 103
1.5					7		3																"	MPF 104
2		6			7		3																"	MPF 105
0.8		6	0.075		7		3							2.5	1 K	1 M							"	MPF 109
																							"	MPF 110
0.5	3		0.02		4.5		1.5																"	MPF 111
0.5																							TO-72	NF520
0.5																							"	NF521
0.5																							"	NF522
0.5																							"	NF523
0.5																							TO-18	NF530
0.5																							"	NF531
0.5																							"	NF532
0.5																							"	NF533
1		5			7		3																"	NF5457
1.5		5.5			7		3																"	NF5458
2		6			7		3																"	NF5459
1		4			6		2																TO-106 Epoxy	KE4220
2		5			6		2																"	KE4221
2.5		6			6		2																"	KE4222
1.3		4	0.02		6		3																TO-92 Epoxy	TIS58
2		6.5			8		4							2									TO-18	UC714
2.5		6	0.05		5		1	2									10	14	400	3.3	4		TO-72	MFE2000
4		8	0.075		5		1	2									10	14	400	3.3	4		"	MFE2001
					16		5		80														TO-18	MFE2004
					16		5		50						ton=60nS	max							"	MFE2005
					16		5		30						" 35								"	MFE2006
					30		15		40						" 20								"	MFE2007
					30		15		30						" 16								"	MFE2008
					30		15		20						" 16								"	MFE2009
					50		20		25						" 16								"	MFE2010
					50		20		15						" 16								"	MFE2011
					50		20		10						" 16								"	MFE2012
1.5	3.5	6	0.02	4.5	6	1.2	3							1	10	500 k							TO-72	2N5556
1.5	3.5	6	0.02	4.5	6	1.2	3							1	10	500 k							"	2N5557
1.5	3.5	6	0.02	4.5	6	1.2	3							1	10	500 k							"	2N5558
0.2		1	0.025		5		1.5																TO-96 Epoxy	2N5716
0.4		1.6	0.025		5		1.5																"	2N5717
0.5		2	(μS) 0.025		5		1.5																"	2N5718
0.25	0.4	0.5	0.5	1.5	4	6	1.2	2		2.5k													TO-72	MFE2093

型名	社名	用途	構造	最大定格 (T _a =25°C)						電氣的特性 (T _a =25°C)						
				V _{CD} (V)	V _{DS} (V)	V _{GS} (V)	I _C I _D (mA)	P _d (mW)	T _j (°C)	I _{GSS} (nA) typ	I _{GSS} (pA) max	I _{DSS} (nA) typ	I _{DSS} (nA) max	V _P , V _{th} *(V)		
MFE2094	MOT	一般	J	-50	50	-50	3	300	175		-0.1	0.4	0.7	1.4	-3	-4.5
MFE2095	"	"	"	-50	50	-50	3	300	175		-0.1	1	1.5	3	-4.5	-5.5
MMT3823	"	VHF, RF	"	-30	30	-30	10	225	135		-1	5		20		-8
JF1033	"	"	"		25	-25	10	310	150		-100	2.5		20		-8
JF1034	"	一般	"		25	-25	10	310	150		-10	0.3		12		-6
TIS59	TI	"	"	-25	25	-25	10	360	150		-4	6		25	-1	-9
UC703	SOL	"	"			-40					-0.1	0.1		10		-6
UC704	"	"	"			-40					-0.2	0.2		2.4		-8
UC705	"	"	"			-40					-0.5	0.5		50		-8
UC707	"	"	"			-20					-2.5	2.5		250		-12
UC714E	"	"	"			-30					-2	2		20		-8
UC751	"	"	"			-30					-0.1	0.1				-6
UC752	"	"	"			-30					-0.3	0.3				-6
UC753	"	"	"			-30					-0.9	0.9				-6
UC754	"	"	"			-30					-0.5	0.5				-4
UC755	"	"	"			-30					-4	4		10		-6
UC756	"	"	"			-30					-0.5	0.5		15		-10
2N4417	"	VHF,UHF,RF	"			-30					-0.1	5		15		-6
UC155	"	SW	"			-30					-0.1	10				-10
UC155E	"	"	"			-30					0.1	10				-10
UC155W	"	"	"			-30					-0.1	10				-10
UC201	"	"	"			-50					-0.1	15				-8
UC401	"	"	"			-30					-0.1	8				-8
UC807	"	"	"			-20					-2	1		125		-12
UC200	"	低雑音	"			-50					-0.1	10		30		-6
UC210	"	"	"			-50					-0.1	4		12		-4
UC220	"	"	"			-50					-0.1	1		5		-2.5
UC241	"	"	"			-50					-0.25	1		10		-5
FM1100	NS	一般	J			-35					-0.1	0.1		1.2	-0.5	-3
FM1100A	"	"	"			-35						0.1		1.2	-0.5	-3
FM1101	"	"	"			-35					-0.1	0.1		1.2	-0.5	-3
FM1101A	"	"	"			-35						0.1		1.2	-0.5	-3
FM1102	"	"	"			-35					-0.1	0.1		1.2	-0.5	-3
FM1102A	"	"	"			-35						0.1		1.2	-0.5	-3
FM1103	"	"	"			-35					-0.1	0.1		1.2	-0.5	-3
FM1103A	"	"	"			-35						0.1		1.2	-0.5	-3
FM1104	"	"	"			-35					-0.1	0.1		1.2	-0.5	-3
FM1104A	"	"	"			-35						0.1		1.2	-0.5	-3
FM1105	"	"	"			-35					-0.1	1		10	-1	-6
FM1105A	"	"	"			-35						1		10	-1	-6
FM1106	"	"	"			-35					-0.1	1		10	-1	-6
FM1106A	"	"	"			-35						1		10	-1	-6
FM1107	"	"	"			-35					-0.1	1		10	-1	-6
FM1107A	"	"	"			-35						1		10	-1	-6
FM1108	"	"	"			-35					-0.1	1		10	-1	-6
FM1108A	"	"	"			-35						1		10	-1	-6
FM1109	"	"	"			-35					-0.1	1		10	-1	-6
FM1109A	"	"	"			-35						1		10	-1	-6
FM1110	"	"	"			-25					-1	0.1		10	-0.5	-10
FM1110A	"	"	"			-25						0.1		10	-0.5	-10
FM1111	"	"	"			-25					-1	0.1		10	-0.5	-10
FM1111A	"	"	"			-25						0.1		10	-0.5	-10
FM1200	"	"	"			-35					-0.2	0.2		2.5	-0.5	-2
FM1201	"	"	"			-35					-0.2	0.2		2.5	-0.5	-2
FM1202	"	"	"			-35					-0.2	0.2		2.5	-0.5	-2
FM1203	"	"	"			-35					-0.2	0.2		2.5	-0.5	-2
FM1204	"	"	"			-35					-0.2	0.2		2.5	-0.5	-2
FM1205	"	"	"			-35					-0.2	2		20	-1	-7

電 氣 的 特 性 (Ta = 25°C)

g _m (m ²)			g _{os} (m ²)			C _{is} (pF)		C _{rs} (pF)		C _{os} (pF)		R _{DS(ON)} (Ω)		NF(dB)		PG(dB)		NF(dB)		外 形	型 名		
min	typ	max	typ	max	typ	max	typ	max	typ	max	typ	max	typ	max	f(Hz)	R _g (Ω)	min	typ	f(MHz)			typ	max
0.35	0.5	0.7	1(μ ²)	3	4	6	1.2	2			1.6K										TO-72	MFE2094	
0.4	0.6	0.8	4(μ ²)	10	4	6	1.2	2			1.3K										"	MFE2095	
3	8	13	0.025		4		1												100	2		微型T	MMT3823
4.5	8	13			1.2		1.2			2							20		100		2.5	TO-92 Epoxy	JF1033
1	3	5	0.01		4.5		1.5						1	1 K	100K							"	JF1034
2.3		5		0.05		6		3														"	TIS59
0.5		5				6								2								TO-72	UC703
1		10				8								2								"	UC704
2		20				12								2								"	UC705
5		50				30																TO-18	UC707
2		6.5				8		4						2								TO-106	UC714E
0.35						10																TO-18	UC751
1						17																"	UC752
2.5						25																"	UC753
1						6		3						2								"	UC754
2						6		3						2								"	UC755
1						6		3						3								"	UC756
4	(400MHz)					3.5		0.8		1.3							10		400		4	微型封装	2N4417
						4		1														TO-72	UC155
						4		1														TO-106	UC155E
						3.5		1														微型封装	UC155W
						7		4														TO-72	UC201
						8		4														TO-72	UC401
						30																TO-18	UC807
.6						7								0.5								TO-72	UC200
4.5						7								0.5								"	UC210
3						7								0.5								"	UC220
2						20								0.02(μV/√Hz)								"	UC241
0.5	3		0.035		5		0.6		V _{G1} -V _{G2} =2 mV max			I _{DSS1} /I _{DSS2} =0.99 mA min								TO-99	FM1100		
0.5	3		0.0035		5		0.6		"	2				"								"	FM1100A
0.5	3		0.035		5		0.6		"	5				"								"	FM1101
0.5	3		0.0035		5		0.6		"	5				"								"	FM1101A
0.5	3		0.035		5		0.6		"	10				"								"	FM1102
0.5	3		0.0035		5		0.6		"	10				"								"	FM1102A
0.5	3		0.035		5		0.6		"	10				"								"	FM1103
0.5	3		0.0035		5		0.6		"	10				"								"	FM1103A
0.5	3		0.035		5		0.6		"	25				"								"	FM1104
0.5	3		0.0035		5		0.6		"	25				"								"	FM1104A
1	6		0.05		5		0.6		"	2				"								"	FM1105
1	6		0.005		5		0.6		"	2				"								"	FM1105A
1	6		0.05		5		0.6		"	5				"								"	FM1106
1	6		0.005		5		0.6		"	5				"								"	FM1106A
1	6		0.05		5		0.6		"	10				"								"	FM1107
1	6		0.005		5		0.6		"	10				"								"	FM1107A
1	6		0.05		5		0.6		"	10				"								"	FM110*
1	6		0.005		5		0.6		"	10				"								"	FM1108A
1	6		0.05		5		0.6		"	25				"								"	FM1109
1	6		0.005		5		0.6		"	25				"								"	FM1109A
0.5	6		0.05		5		0.6		"	10				"								"	FM1110
0.5	6		0.005		5		0.6		"	10				"								"	FM1110A
0.5	6		0.05		5		0.6		"	50				"								"	FM1111
0.5	6		0.005		5		0.6		"	50				"								"	FM1111A
0.8	4.5		0.035		8		1		"	2				"								"	FM1200
0.8	4.5		0.035		8		1		"	5				"								"	FM1201
0.8	4.5		0.035		8		1		"	10				"								"	FM1202
0.8	4.5		0.035		8		1		"	10				"								"	FM1203
0.8	4.5		0.035		8		1		"	25				"								"	FM1204
3	10		0.05		8		1		"	2				"								"	FM1205

型名	社名	用途	構造	最大定格 (Ta=25°C)					電氣的特性 (Ta=25°C)							
				V _{GD} (V)	V _{DS} (V)	V _{GS} (V)	I _G [*] I _D (mA)	P _d (mW)	T _j (°C)	I _{GSS} (nA) typ	I _{GSS} (pA) [*] max	I _{DSS} (mA) min	I _{DSS} (nA) [*] typ	I _{DSS} (nA) [*] max	V _P , V _{th} [*] (V) min	V _P , V _{th} [*] (V) typ
FM1206	NS	一般	J			-35						-0.2	2	20	-1	-7
FM1207	"	"	"			-35						-0.2	2	20	-1	-7
FM1208	"	"	"			-35						-0.2	2	20	-1	-7
FM1209	"	"	"			-35						-0.2	2	20	-1	-7
FM1210	"	"	"			-25						-1	0.2	20	-0.5	-7
FM1211	"	"	"			-25						-1	0.2	20	-0.5	-7
FM3954	"	"	"			-50						-0.1	0.5	5	-1	-4.5
FM3954A	"	"	"			-50						-0.1	0.5	5	-1	-4.5
FM3955	"	"	"			-50						-0.1	0.5	5	-1	-4.5
FM3955A	"	"	"			-50						-0.1	0.5	5	-1	-4.5
FM3956	"	"	"			-50						-0.1	0.5	5	-1	-4.5
FM3957	"	"	"			-50						-0.1	0.5	5	-1	-4.5
FM3958	"	"	"			-50						-0.1	0.5	5	-1	-4.5
2N3921	SOL	"	"			-50						-0.25	1	10		-2.7
2N3922	"	"	"			-50						-0.25	1	10		-2.7
2N3954	"	"	"			-50						-0.1	0.5	5		-4.5
2N3954A	"	"	"			-50						-0.1	0.5	5		-4.5
2N3955	"	"	"			-50						-0.1	0.5	5		-4.5
2N3955A	"	"	"			-50						-0.1	0.5	5		-4.5
2N3956	"	"	"			-50						-0.1	0.5	5		-4.5
2N3957	"	"	"			-50						-0.1	0.5	5		-4.5
2N3958	"	"	"			-50						-0.1	0.5	5		-4.5
2N4084	"	"	"			-50						-0.25	1	10		-2.7
2N4085	"	"	"			-50						-0.25	1	10		-2.7
2N5452	"	"	"			-50						-0.1	0.5	5		-4.5
2N5453	"	"	"			-50						-0.1	0.5	5		-4.5
2N5454	"	"	"			-50						-0.1	0.5	5		-4.5
UC2130	"	"	"			-50						-0.1	0.5	4.5		-5
UC2132	"	"	"			-50						-0.1	0.5	4.5		-5
UC2134	"	"	"			-50						-0.1	0.5	4.5		-5
UC 2136	SOL	一般	J			-50						-0.1	0.5	4.5		-5
UC 2138	"	"	"			-50						-0.1	0.5	4.5		-5
UC 2139	"	"	"			-30						-0.2	0.2	6		-6
UC 2147	"	"	"			-30						-0.2	0.5			-5
UC 2149	"	"	"			-30						-0.2	0.5	15		-6
2N5045	TI	"	"		-50	-50	30	400	175			-0.25	0.5	8	-0.5	-4.5
2N5046	"	"	"		-50	-50	30	400	175			-0.25	0.5	8	-0.5	-4.5
2N5047	"	"	"		-50	-50	30	400	175			-0.25	0.5	8	-0.5	-4.5
MMF1	MOT	"	"		-30	30	-30	10/20	300	175		-25	0.5	10	-0.2	-8
MMF2	"	"	"		-30	30	-30	10/20	300	175		-25	0.5	10	-0.2	-8
MMF3	"	"	"		-30	30	-30	10/20	300	175		-25	0.5	10	-0.2	-8
MMF4	"	"	"		-30	30	-30	10/20	300	175		-25	0.5	10	-0.2	-8
MMF5	"	"	"		-30	30	-30	10/20	300	175		-25	0.5	10	-0.2	-8
MMF6	"	"	"		-30	30	-30	10/20	300	175		-25	0.5	10	-0.2	-8

電 氣 的 特 性 (T _a = 25°C)														外 形	型 名							
g _m (mS)			g _{os} (mS)		C _{is} (pF)		C _{rs} (pF)		C _{os} (pF)		R _{DS(ON)} (Ω)		NF(dB)			PG(dB)		NF(dB)				
min	typ	max	typ	max	typ	max	typ	max	typ	max	typ	max	typ			max	min	typ	f(MHz)	typ	max	
3		10	0.05		8		1		V _{GS1} - V _{GS2} = 5						I _{DSS1} /I _{DSS2} = 0.99min						TO-99	FM1206
3		10	0.05		8		1		"		10				"		0.98				"	FM1207
3		10	0.05		8		1		"		10				"		0.98				"	FM1208
3		10	0.05		8		1		"		25				"		0.95				"	FM1209
0.8		10	0.05		8		1		"		10				"		0.90				"	FM1210
0.8		10	0.05		8		1		"		50				"		0.85				"	FM1211
1		4	0.035		4		1.2		"		5				"		0.95				"	FM3954
1		4	0.035		4		1.2		"		5				"		0.95				"	FM3954A
1		4	0.035		4		1.2		V _{GS1} - V _{GS2} = 10mV max						"		0.95				"	FM3955
1		4	0.035		4		1.2		"		5				"		0.95				"	FM3955A
1		4	0.035		4		1.2		"		15				"		0.95				"	FM3956
1		4	0.035		4		1.2		"		20				"		0.90				"	FM3957
1		4	0.035		4		1.2		"		25				"		0.85				"	FM3956
1.5			0.035						"		5										TO-71	2N3921
1.5			0.035						"		5										"	2N3922
1			0.035						"		5				I _{DSS1} /I _{DSS2} = 0.95 min						"	2N3954
1			0.035						"		5				"		0.95				"	2N3954A
1			0.035						"		10				"		0.95				"	2N3955
1			0.035						"		10				"		0.95				"	2N3955A
1			0.035						"		15				"		0.95				"	2N3956
1			0.035						"		20				"		0.90				"	2N3957
1			0.035						"		25				"		0.85				"	2N3958
1.5			0.035						"		15										"	2N4084
1.5			0.035						"		15										"	2N4085
1			0.001						"		5				I _{DSS1} /I _{DSS2} = 0.95						"	2N5452
1			0.001						"		10				"		0.95				"	2N5453
1			0.001						"		15				"		0.95				"	2N5454
1			0.04						"		5				"		0.95				"	UC2130
1			0.04						"		20				"		0.95				"	UC2132
1			0.04						"		30				"		0.90				"	UC2134
1			0.04						V _{GS1} - V _{GS2} = 50						I _{DSS1} /I _{DSS2} = 0.90					TO-71	UC2136	
1			0.04						"		100				"		0.80				"	UC2138
0.75			0.04																		"	UC2139
1			0.05																		"	UC2147
1			0.04																		"	UC2149
1.5		6	0.025		8		4		V _{GS1} - V _{GS2} = 5 mV max						I _{DSS1} /I _{DSS2} = 0.95min					"	2N5045	
1.5		6	0.025		8		4		"		10				"		0.90				"	2N5046
1.5		6	0.025		8		4		"		15				"		0.80				"	2N5047
1.5		6.5	0.05		6		2		"		5				"		0.95				TO-72 × 2	MMF1
1.5		6.5	0.05		6		2		"		5				"		0.95				"	MMF2
1.5		6.5	0.05		6		2		"		5				"		0.90				"	MMF3
1.5		6.5	0.05		6		2		"		5				"		0.90				"	MMF4
1.5		6.5	0.05		6		2		"		5				"		0.90				"	MMF5
1.5		6.5	0.05		6		2		"		5				"		0.90				"	MMF6

型名	社名	用途	構造	最大定格 (Ta=25°C)						電氣的特性 (Ta=25°C)					
				V _{GD} (V)	V _{DS} (V)	V _{GS} (V)	I _G [*] I _D (mA)	P _d (mW)	T _j (°C)	I _{GSS} (nA) typ	(pA) [*] max	I _{DSS} (mA) min	(nA) [*] typ max	V _P , V _{th} [*] (V) min typ max	
MEM511	G I C	SW-CHOPPER	MOS	30	-30	30		225				50 []	-0.5 [*]	-3 [*]	-6 [*]
MEM511C	"	"	"	25	-25	25		175				50 []	-3 [*]	-3 [*]	-6 [*]
MEM517	"	"	"	25	-30	25		600				0.15	-0.8 []	-2.5 [*]	-5 [*]
MEM517A	"	"	"	25	-30	25		600				0.15	-0.8 []	-2.5 [*]	-5 [*]
MEM517B	"	"	"	25	-30	25		300				0.15	-0.8 []	-2.5 [*]	-5 [*]
MEM517C	"	"	"	25	-25	25		450				0.15	-3.5 []	-2.5 [*]	-5 [*]
MEM520	"	"	"	40	-30	40		225				0.03 [*]	-0.5 [*]	-3 [*]	-6 [*]
MEM520C	"	"	"	25	-25	25		175				0.1 [*]	-3 [*]	-3 [*]	-6 [*]
MEM556	"	"	"	50	-50	50		100				0.1	-0.1 []	-3 [*]	-6 [*]
MEM556C	"	"	"	45	-45	45		100				0.3	-0.3 []	-3 [*]	-6 [*]
MEM560	"	"	"	35	-35	35		300				0.1	-1 []	-1.5 [*]	-3 [*]
MEM560C	"	"	"	30	-30	30		200				0.2	-2 []	-1.5 [*]	-3 [*]
MEM561	"	"	"	40	-35	50		300				0.05 [*]	-1 [*]	-1.5 [*]	-3 [*]
MEM575	"	"	"	25	-25	25		300				0.2	-1 []	-1 [*]	-3.5 [*]
MEM803	"	"	"	20	-20	20		150				0.2	-3 []	-2 [*]	-6.5 [*]
MEM804	"	"	"	35	-30	40		225				0.1 [*]	-2 [*]	-1 [*]	-3 [*]
2N3608	"	"	"	40	-30	30		500				0.1 [*]	-1 [*]	-4 [*]	-6 [*]
2N4120	"	"	"	40	-30	40		350				0.1	-0.1 []	-3 [*]	-6 [*]
2N4353	"	"	"	30	-30	30		250				0.1	-0.5 []	-3 [*]	-5 [*]
3N162	"	"	"	25	-30	25		600				0.2	-10 []	-2.5 [*]	-5 [*]
3N163	G I C, SOL	"	"	40	-40	40		375				10 [*]	-0.1 [*]	-2 [*]	-5 [*]
3N164	"	"	"	30	-30	30		375				10 [*]	-0.2 [*]	-2 [*]	-5 [*]
3N167	G I C	"	"	30	-30	30		225				70 [*]	-0.03 [*]	-2 [*]	-6 [*]
3N168	"	"	"	25	-25	25		225				0.4	-0.08 [*]	-2 [*]	-6 [*]
3N172	G I C, SOL	"	"	40	-40	40		375				0.1	-0.3 [*]	-2 [*]	-5 [*]
3N173	"	"	"	40	-40	40		375				0.3	-6 [*]	-2 [*]	-5 [*]
3N174	G I C	"	"	30	-30	30		360				2 [*]	-3 [*]	-2 [*]	-6 [*]
3N178	"	"	"	75	-75	45		100				0.15	-0.1 []	-4.5 [*]	-5.5 [*]
3N179	"	"	"	60	-60	45		100				0.2	-0.3 []	-4 [*]	-6 [*]
3N180	"	"	"	40	-40	45		100				0.3	-0.3 []	-3 [*]	-6 [*]
3N181	G I C	SW-CHOPPER	MOS	30	-30	25		300				0.15	-0.3 []	-3 [*]	-4 [*]
3N182	"	"	"	30	-30	25		300				0.2	-1 []	-2.5 [*]	-5 [*]
3N183	"	"	"	25	-25	25		300				0.3	-2 []	-2 [*]	-6 [*]
3N184	"	"	"	35	-35	35		300				50 []	-0.5 [*]	-2 [*]	-3 [*]
3N185	"	"	"	30	-30	30		300				0.1	-1 []	-1.5 [*]	-3 [*]
3N186	"	"	"	25	-25	25		300				0.2	-2 []	-1 [*]	-3.5 [*]
UC1764	SOL	"	"		-30							10 [*]	-10 [*]	-2 [*]	-5 [*]
3N160	T I	"	"	25	-25	±25	-125	360	200			±10 [*]	-10 [*]	-1.5 [*]	-5 [*]
3N155	MOT	"	"	35	-35	50	-30	300	175			1	-1 [*]	-1.5 [*]	-3.2 [*]
3N155A	"	"	"	35	-35	50	-30	300	175			1	-0.25 [*]	-1.5 [*]	-3.2 [*]
3N156	"	"	"	35	-35	50	-30	300	175			1	-1 [*]	-3 [*]	-5 [*]
3N156A	"	"	"	35	-35	50	-30	300	175			1	-0.25 [*]	-3 [*]	-5 [*]
2N4352	"	"	"	30	-25	±30	-30	300	175			±10 [*]	-10 [*]	-1 [*]	-5 [*]
3N157	"	"	"	35	-35	50	-30	300	175			10 [*]	-1 [*]	-1.5 [*]	-3.2 [*]
3N157A	"	"	"	50	-50	50	-30	300	175			10 [*]	-0.25 [*]	-1.5 [*]	-3.2 [*]
3N158	"	"	"	35	-35	50	-30	300	175			10 [*]	-1 [*]	-3 [*]	-5 [*]
3N158A	"	"	"	50	-50	50	-30	300	175			10 [*]	-0.25 [*]	-3 [*]	-5 [*]
MFE3003	"	"	"	20	-15	±30	-30	300	175			±0.1	-10 [*]		-4 [*]
MEM550	G I C	SW-CHOPPER	MOS	30	-30			250				0.1		-3 []	-6 [*]
MEM550C	"	"	"	25	-25			170				0.2		-3 []	-6 [*]
MEM551	"	"	"	40	-30			250				30 [*]		-3 [*]	-6 [*]
MEM551C	"	"	"	25	-25			170				1		-3 [*]	-6 [*]
2N4066	G I C, MOT	"	"	25	-30	±25	-200	600	175			0.5	-1 [*]	-3 [*]	-6 [*]
2N4067	"	"	"	25	-30	±25	-200	600	175			0.5	-1 [*]	-3 [*]	-6 [*]
3N151	G I C	"	"	30	-30			325				50 []		-3 [*]	-6 [*]
3N165	G I C, SOL	"	"	40	-40			600				50		-3 [*]	-6.5 [*]
3N166	"	"	"	40	-40			600				50		-2 [*]	-5 [*]
UC2766	SOL	"	"		-30							10 [*]	-10 [*]		
MFE3020	MOT	"	"	25	-25	±25	-200	600	175				-10 [*]	-2 [*]	-6 [*]

* 附有閘極保護電路

電 氣 的 特 性 (T_a = 25°C)

g _m (mS)		g _{os} (mS)		C _{is} (pF)		C _{rs} (pF)		C _{os} (pF)		R _{DS(ON)} (Ω)		NF(dB)		PG(dB)		NF(dB)		外 形	型 名		
min	typ	max	typ	max	typ	max	typ	max	typ	max	typ	max	f(Hz)	R _g (Ω)	min	typ	max			f(MHz)	typ
2.5					3.5		2.5				150								TO-72	MEM511	
2.5					4		4				150								"	MEM511C	
12					10		10				35								TO-33	MEM517	
12					10		10				35								TO-5	MEM517A	
12					10		10				35								TO-72	MEM517B	
12					10		10				35								TO-33	MEM517C	
2.5					3		2.5				150								TO-72	MEM520	
2.5					3		2.5				150								"	MEM520C	
0.95					0.3		0.3				700								"	MEM556	
0.95					0.4		0.4				700								"	MEM556C	
3.5					7.5		3				100								"	MEM560	
3					8		4				175								"	MEM560C	
0.35					6.5		2.5				100								"	MEM561	
18					45		15				13								"	MEM575	
1					4.5		4				200								"	MEM803	
3					7		3				175								"	MEM804	
2					4		3.5				150								TO-33	2N3608	
0.9					3		2.5				600								TO-72	2N4120	
3					6		3				125								"	2N4353	
13					10		5				40								TO-33	3N162	
3					2		0.7				200								TO-72	3N163	
3					2		0.7				250								"	3N164	
					3.5		12				17								"	3N167	
					3.5		12				35								"	3N168	
3					3		0.8				200								"	3N172	
3					3		0.8				300								"	3N173	
2					3.5		0.6				800								"	3N174	
1					0.3		0.2				750								"	3N178	
0.85					0.4		0.3				800								"	3N179	
0.85					0.45		0.4				900								"	3N180	
12.5					12		6.5				35								TO-72	3N181	
10					12		7				40								"	3N182	
9					15		10				50								"	3N183	
3.5					7		3				80								"	3N184	
3					8		4				125								"	3N185	
2.8					8		4				150								"	3N186	
1	4				3	1					300		2						"	UC1764	
3.5	6.5	0.25			10	4														3N160	
1	4				5	1.3					600									3N155	
1	4				5	1.3					300									3N155A	
1	4				5	1.3					600									3N156	
1	4				5	1.3					300									3N156A	
1					5	1.3														2N4352	
1	4	0.06			5	1.3					300	100	0							3N157	
1	4	0.06			5	1.3					"	100	0							3N157A	
1	4	0.06			5	1.3					"	100	0							3N158	
1	4	0.06			5	1.3					"	100	0							3N158A	
					5	1					200									MFE3003	
1.5					1.1	1.1					250									TO-78	MEM550
0.8					2	2					250									"	MEM550C
1					1.1	1.1					250									"	MEM551
0.75					1.5	1.5					250									"	MEM551C
1.5		0.3			7	1.5					500									TO-76	2N4066
2.5		0.3			7	1.5					250									"	2N4067
2					5	2					250									TO-78	3N151
2					2.5	0.7					250									TO-99	3N165
2					2.5	0.7					250									"	3N166
						1					300									"	UC2766
0.5					7	1.5					500									TO-76	MFE3020

型名	社名	用途	構造	最大定格 (Ta=25°C)					電氣的特性 (Ta=25°C)							
				V _{GD} (V)	V _{DS} (V)	V _{GS} (V)	-I _G I _D (mA)	P _d (mW)	T _j (°C)	I _{css} (nA) typ	I _{css} (pA) max	I _{DSS} (mA) min	I _{DSS} (nA) typ	I _{DSS} (nA) max	V _P , V _{th} (V) min	V _P , V _{th} (V) typ
MEM557	GIC	SW-CHOPPER	MOS	±30	20	±10		225		-10*			5		-0.3	-4
MEM557C	"	"	"	±30	20	±10		150		-50*			4		-0.3	-4
MEM562	"	"	"	±30	20	±10		225		-1*		1*		0.5*	4*	
MEM562C	"	"	"	±30	20	±10		175		-10*		2*		0.5*	4*	
MEM563	"	"	"	±30	20	±10		225		-1*		1*		0.5*	4*	
MEM563C	"	"	"	±30	20	±10		175		-10*		3*		0.5*	4*	
*MEM655	"	"	"	+6 -30	20	±6		225		±10			4			-4
*MEM660	"	"	"	+12 -30	20	±12		150		±2			3		-0.3	-4
2N4038	"	"	"	±50	15	±50		150								-2
3N138	GIC, RCA	"	"		35	±10	50	400	175		-10*					-10
3N153	"	"	"		20	+6 -8	50	400	175		-50*					-8
3N169	GIC, MOT	"	"	±35	25	±35	30	300	175		-10*		10*	0.5*	1.5*	
3N170	"	"	"	±35	25	±35	30	300	175		-10*		10*	1*	2*	
3N171	"	"	"	±35	25	±35	30	300	175		-10*		10*	1.5*	3*	
3N175	GIC	"	"	-30	30	-35		225		-10*		1*		1*	2*	
3N176	"	"	"	-25	25	-30		225		-30*		3*		1*	2.5*	
3N177	"	"	"	-20	20	-20		225		-50*		5*		1*	3.5*	
MEM571C	"	VHF, RF	"		20	±6		150					4			
3N128	GIC, RCA	"	"		20	+1 -8	50	330	175		-50*				-3	-8
3N142	"	"	"		20	+1 -8	50	330	175		-1				-3	-8
3N152	"	"	"		20	+1 -8	50	330	175		-1				-3	-8
3N154	"	"	"		20	+1 -8	50	330	175		-50*				-3	-8
3N139	RCA	一般	"		35	±10	50	330	175		-1					-6
3N143	"	VHF, MIX	"		20	+1 -8	50	330	175		-1				-3	-8
40467A	"	VHF, RF	"		20	+1 -8	50	330	175		-1					-8
40468A	"	"	"		20	+1 -8	25	330	175		-1					-8
40559A	"	VHF, MIX	"		20	+1 -8	25	330	175		-1*					-8
MFE3004	MOT	VHF, RF	"	-20	20	±30	10	300	175		±50*	2	10			-5
MFE3005	"	"	"	-20	20	±30	10	300	175		±50*	2	10			-5
MFE3002	"	CHOPPER	"	-20	15	±30	30	300	175		100*		10*			3*
2N3796	MOT	低周波	MOS		25	±30	20	300	200		-1*	0.5	1.5	3		-3 -4
2N3797	"	"	"		20	±30	20	300	200		-1*	2	2.9	6		-5 -7
MFE3001	"	"	"		20	±30	20	300	200		-10*	0.5		6		-8
2N4351	"	SW	"	-30	25	±30	30	300	175		±10*		10*	1*		5*
3N124	"	一般	J	-50	50	-50	20 20	300	175		-0.25	0.2	2			-5
3N125	"	"	"	-50	50	-50	20 20	300	175		-0.25	1.5	4.5			-8
3N126	"	"	"	-50	50	-50	20 20	300	175		-0.25	3	9			-18

* 附有閘極保護電路

電 氣 的 特 性 (T _a = 25°C)															外 形	型 名								
g _m (mS)			g _{os} (mS)		C _{is} (pF)		C _{rs} (pF)		C _{os} (pF)		R _{DS(ON)} (Ω)		NF(dB)				PG(bB)		NF(dB)					
min	typ	max	typ	max	typ	max	typ	max	typ	max	typ	max	typ	max			f(Hz)	R _a (Ω)	min	typ	f(MHz)	typ	max	
	10				30		0.32				200				t _{ON} =30nS typ,				t _{OFF} =65nS typ			TO-72	MEM557	
	8				3		0.32				200				" 40				" 75			"	MEM557C	
	2.5				3		0.3				150				" 60				" 85			"	MEM562	
	2				3		0.5				150				" 85				" 120			"	MEM562C	
	5				4		0.3				40				" 25				" 75			"	MEM563	
	4				4		0.4				50				" 30				" 100			"	MEM563C	
	10				4		0.32				30				" 25				" 45			"	MEM655	
	10				4.5		0.3				30				" 20				" 35			"	MEM660	
	2				3		0.2															"	2N4038	
	6				3		0.2				180											"	3N138	
	10				6		0.34				200											"	3N153	
1					5		1.3				200				I _{D(ON)} = 10mA min							"	3N169	
1					5		1.3				200				" 10 "							"	3N170	
1					5		1.3				200				" 10 "							"	3N171	
	2.5				3		0.3				120				" 25mA typ							"	3N175	
	2				4		0.4				200				" 20 "							"	3N176	
	1.5				5		0.5				300				" 15 "							"	3N177	
					4		0.32											17	200	2.5		"	MEM571C	
5	7.5				5.5	0.16	0.28				200						13.5	16	200	3.5	5	"	3N128	
5	7.5				5.5	0.16	0.28				200						16		100	2.5	4	"	3N142	
5	7.5				5.5	0.16	0.28										14.5	16	200	2.5	3.5	"	3N152	
5	7.5				5.5	0.16	0.28										13	5	16	200	3.5	5	"	3N154
3	6				3	0.2					200						(CG)					"	3N139	
5	7.5				5.5	0.17	0.3										10	13.5	200-30			"	3N143	
4	7.5				5.5	0.16	0.28										12	16	200	3.5	5	"	40467A	
	7.5				5.5	0.17	0.28										14	17	100	3.5	5	"	40468A	
	2.8(gc)				5.5	0.17	0.3										(CG) 22		100-10.7			"	40559A	
2					4.5	0.2											16		200		4.5	"	MFE3004	
2					4.5	0.2											10		400		4.5	"	MFE3005	
					5	1					100											"	MFE3002	
0.9	1.2	1.8	0.012	0.025	5	7	0.5	0.8					3.8	1 k	3 M							TO-18	2N3796	
1.5	2.3	3	0.027	0.060	6	8	0.5	0.8					3.8	1 k	3 M							"	2N3797	
0.7		3.5		0.1	5		1.5															TO-72	MFE3001	
1				(μS)	5		1.3				300				I _{D(ON)} = 3mA min							"	2N4351	
0.25		1		2	5		0.5				1 k		4	1 k	1 M							"	3N124	
0.4		1.6		0.01	5		0.5				750		4	1 k	1 M							"	3N125	
0.6		2.7		0.02	5		0.5				500		4	1 k	1 M							"	3N126	

型名	社名	用途	構造	最大定格 (T _a =25°C)							電氣的特性 (T _a =25°C)					
				V _{GD} (V)	V _{DS} (V)	V _{GIS} (V)	V _{G2S} (V)	I _D (mA)	P _d (mW)	T _j (°C)	I _{G1SS} , I _{G2SS} (nA) typ	I _{G1SS} , I _{G2SS} (pA) max	I _{DSS} (mA) min	I _{DSS} (mA) typ	I _{DSS} (mA) max	V _{P1} , V _{P2} (V) typ
* FT0601	FC	VHF RF	MOS		25	+1/-6	±6	50	330	175		±20	5	30	-1.5	-4
MEM554	GIC	"	"		20	+5/-10	±20		225		10*		5		-1.5	
MEM554C	"	"	"		20	+5/-10	±20		150		50*		5		-1.5	
* MEM564C	"	"	"		20	±6	±6		225		1		5		-1.5	
* MEM614	"	"	"		20	±6	±6		225		1		5		-1	
3N141	RCA, GIC	DC UHF MIX	"		20	+1/-8	-8/40% V _{DS}	50	330	175		1			-2	-4
3N159	RCA	VHF RF	"		20	+1/-8	"	50	330	175		1			-2	-4
* 3N187	RCA, GIC	VHF RF-MIX	"		20	+3/-6	-6/30% V _{DS}	50	330	175		50			-2	
* 3N200	RCA, GIC	UHF RF-MIX	"		20	+3/-6	"	50	330	175		50			-1	
* 40819	RCA	VHF RF-MIX	"		25	+3/-6	-6/40% V _{DS}	50	330	175		50			-2	
40600	"	VHF RF	"		20	+1/-8	-8/40% V _{DS}	50	330	175		1			-3	
40601	"	VHF MIX	"		20	+1/-8	"	50	330	175		1			-3	
40602	"	VHF IF	"		20	+1/-8	"	50	330	175		1			-3	
40603	"	FM RF	"		20	+1/-8	"	50	330	175		1			-3	
40604	"	FM MIX	"		20	+1/-8	"	50	330	175		1			-3	
* 40673	"	UHF RF-MIX	"		20	+1/-6	-6/30% V _{DS}	50	330	175		50			-2	
* 40820	"	VHF RF	"		20	+3/-6	-6/40% V _{DS}	50	330	175		50			-1	
* 40821	"	VHF MIX	"		20	+3/4.5	4.5/40% V _{DS}	50	330	175		50			-1	
* 40822	"	FM RF	"		18	+3/-6	-6/40% V _{DS}	50	330	175		50			-2	
* 40823	"	FM MIX	"		18	+3/4.5	4.5/40% V _{DS}	50	330	175		50			-2	
* MFE120	MOT	VHF RF	"		25			30	300	200		20	2	7	18	-4
* MFE121	"	"	"		25			30	300	200		20	5	10	30	-4
* MFE122	"	VHF MIX	"		25			30	300	200		20	2	9	20	-4
MFE3006	"	VHF RF	"		25	±35	±35	30	300	175		1	2	7	18	-3
MFE3007	"	"	"		25	±35	±35	30	300	175		1	5	10	20	-3
MFE3008	"	VHF MIX	"		25	±35	±35	30	300	175		1	2	9	20	-3
* MPF120	"	VHF RF	"		25			30	500	175		20	2	7	18	-4
* MPF121	"	"	"		25			30	500	175		20	5	10	30	-4
* MPF122	"	VHF MIX	"		25			30	500	175		20	2	9	20	-4
* MPF1000	"	UHF RF	"		25			30	500	175		20	5	7	15	-3

*附有閘極保護電路

電 気 的 特 性 (T _a = 25°C)													其 他	外 形	型 名	
g _m (mS)			C _{is} (pF)		C _{rs} (pF)		C _{os} (pF)		PG (dB)		NF (dB)					
min	typ	max	typ	max	typ	max	typ	max	min	typ	f (MHz)	typ				max
7	11		7	10	0.03	0.04	2.6	3.5	16	19	200	2.5	4		TO-72	* FT0601
	13		5		0.02					20	200	2.8			"	MEM554
	11		5		0.02					18	200	3.5			"	MEM554C
	12		5		0.02					17	200	3.5			"	* MEM564C
	10		5		0.02					22	200	3.5			"	* MEM614
6	10		5.5		0.02	0.03				(CG) 17	200→30				"	3N141
7	10		5.5		0.02	0.03			16	18	200	2.5	3.5		"	3N159
7	12		6		0.02	0.03			16	18	200	3.5	4.5		"	* 3N187
10	15		6		0.02	0.03			10	12.5	400	4.5	6		"	* 3N200
	12		6		0.02	0.03			14	18	200	3.5	6		"	* 40819
	10		5.5		0.02	0.03				20	200		5		"	40600
	(gc) 2.7		5.5		0.02	0.03				(CG) 14	200				"	40601
	10		5.5		0.02	0.03				28	44				"	40602
	10		5.5		0.02	0.03				(max) 24	100	3	4		"	40603
	(gc) 2.8		5.5		0.02	0.03				(CG) 23	100→10.7				"	40604
	12		6		0.02	0.03			14	18	200	3.5	6		"	* 40673
	12		6		0.02	0.03			14	17	200	4.5	6		"	* 40820
	12		6		0.02	0.04			(CG) 11		200→44				"	* 40821
	12		6.5		0.02	0.03			19	24	100	2	3.5		"	* 40822
	12		6.5		0.025	0.045			(CG) 14	18	100→10.7				"	* 40823
8		18	4.5	7	0.023				17	19.6	105	2.9	5		"	* MFE120
10		20	4.5	6	0.023				17	18.6	200	2.6	5		"	* MFE121
8		18	4.5	7	0.023				(CG) 12	13.3	200→44				"	* MFE122
8		18	4.5	6	0.02	2.5	4		20	25	100	2.5	4		"	MFE3006
10		18	4.5	5.5	0.02	2.5	3.5		18	21	200	3	4		"	MFE3007
8		18	4.5	6	0.02	2.5	4		10	13	200→30				"	MFE3008
8		18	4.5	7	0.023	2.5	4		17	19.6	105	2.9	5		plastic	* MPF120
10		20	4.5	6	0.023	2.5	3.5		17	18.6	200	2.6	5		"	* MPF121
8		18	4.5	7	0.023	2.5	4		(CG) 12	13.3	200→44				"	* MPF122
10	15	20	4	5.5	0.02	2.2			7	10	850	7			"	* MPF1000

應用電路圖選

[電路①] 不平衡直接交連式放大器

(增益 62dB)

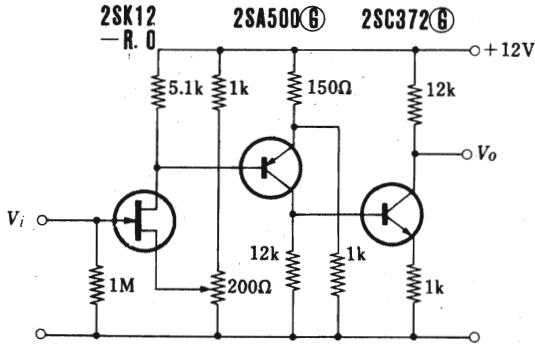

直流放大電路

[電路①] 這直流放大電路是採用 FET 與普通 PNP 晶體管組成，前級 FET 的洩漏電流，是有負溫度特性，故是用來補償下級的 V_{BE} 因溫度引起的變化。

[電路②] 同樣是三級的放大電路，不過電路②是採用 NPN 的晶體管，電路②的末級是採用射極輸出接法，

所以它的增益，是比較電路①低，只得 40dB 增益。①與②中的第二級，同樣在射極上接有分流電阻，這是用來調整偏壓用的。

場效應晶體管的 I_D 與 g_m 兩個參數（特別是結型的場效應管）它的溫度係數，是跟偏壓而作有規則的變化，所以選擇適當的偏壓，可以找到一個零的溫度係數，故最適宜用於要求溫度漂移度小的放大器上。如果要

求特別低溫度漂移的話，可以採用以下的差動式放大器。

[電路③] 是不平衡式的三級差動放大器，負回輸因極性的關係，所以接於與輸入配成對的 FET 的閘極上。

[電路④] 也是差動式放大器，不過它是平衡輸入式的三級放大器，前級是定電流電路，級與級之間採用射極輸出式交連，末級用互補式高級放大器形式。

[電路②] 三級直接交連放大器

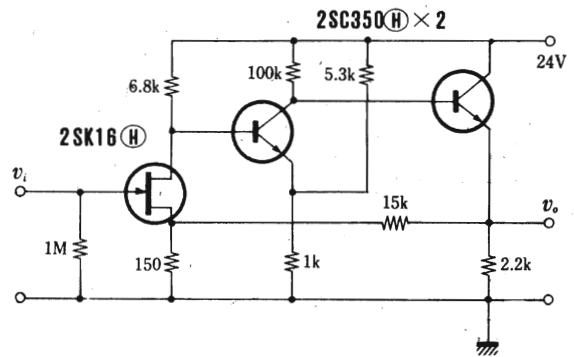

[電路③] 差動式直流放大電路

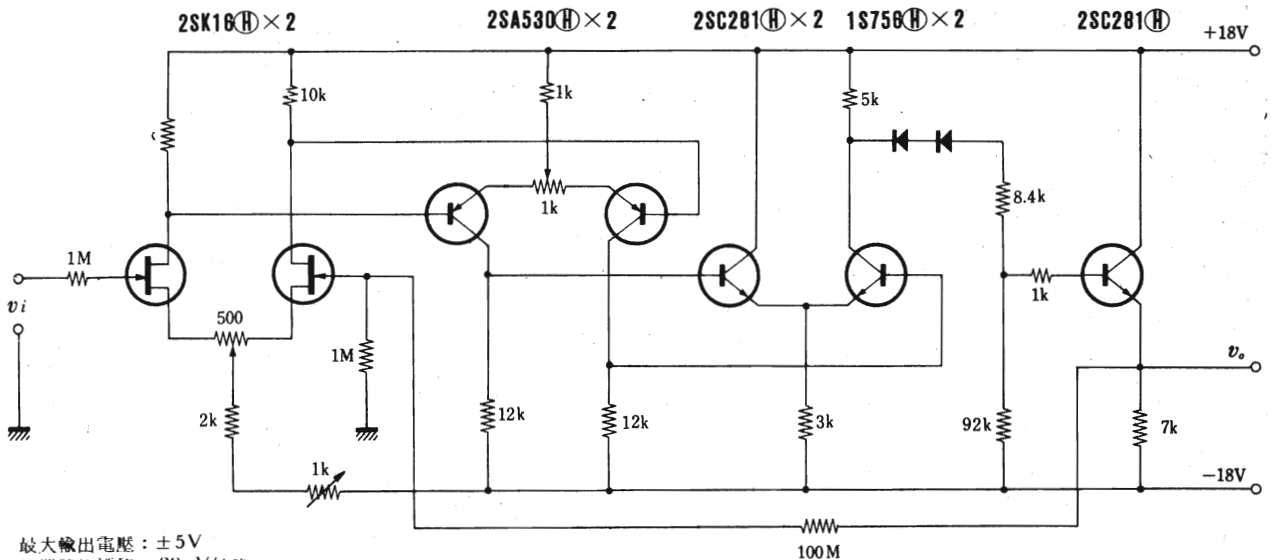

最大輸出電壓：±5V
 放置時的漂移：20μV/小時
 頻率範圍：DC~15Hz (-3dB)

[電路④] 三級差動放大器 (增益 98dB)

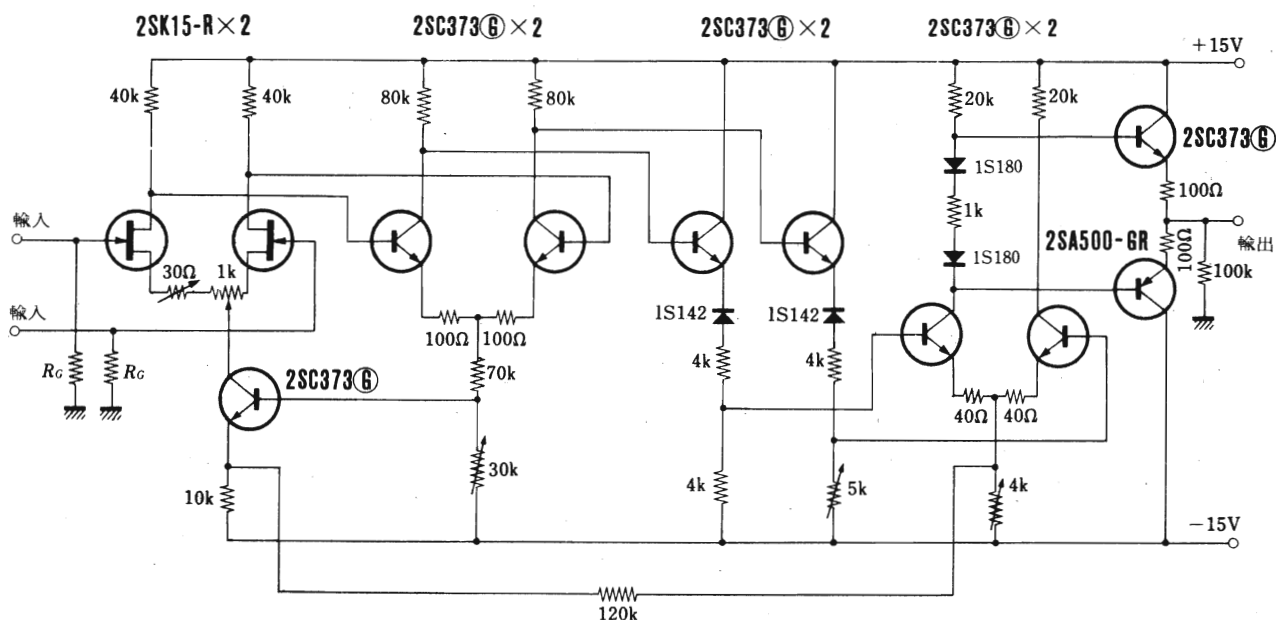

[電路⑤] DC/AC 電壓計

性能 輸入電壓範圍：0~1000V
 頻率帶域寬：DC~1KHz
 輸入阻抗：10MΩ

3SK20(H) × 2

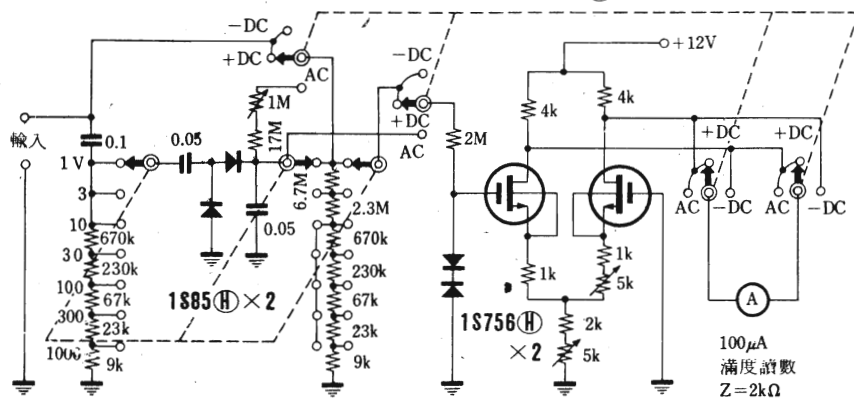

輸入輸出特性

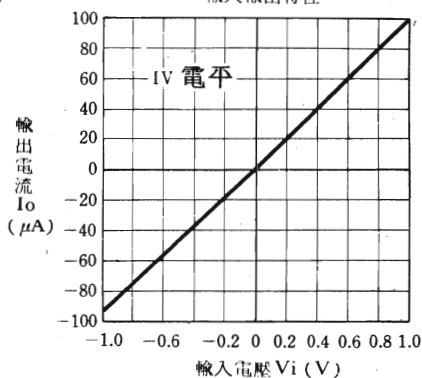

[電路⑦] 心電表、腦波表用前級放大器

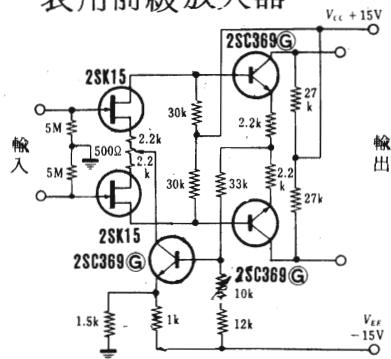

[電路⑤] 是利用差動放大器的 DC/AC 電壓表，因為採用 MOS 型的場效應管，所以在閘極上加上二極管作保護用，在源極上所接的電阻，是用來調整零電位用。

「性能」輸入電壓範圍：0~1000V
 頻率帶寬：DC~1KHz
 輸入阻抗：10MΩ

因 FET 有高輸入阻抗的特性，所以很多醫療用機器均加以利用，例如 [電路⑥] 是其中之一例，這是一種測量肌肉的電壓的前置放大器，由

電路的輸出部份，加接一個電容器交連至輸入的閘極。這是利用正回輸的逆相位電容器，來抵消輸入端同軸輸入綫對地的漂移電容量。

[電路⑦] 是心電表與腦波表所用的前置放大器，這種放大器對於雜音方面，要求十分嚴格，所以採用低雜音性的結型 FET 為主幹。

FET 在物理化學的測量方面，也相當活躍，[電路⑧] 是測量 pH 值的電路，因為要測量出有 100MΩ 阻抗的玻璃電極所產生的直流電壓，

[電路⑥] 測量肌肉電壓的前級放大器

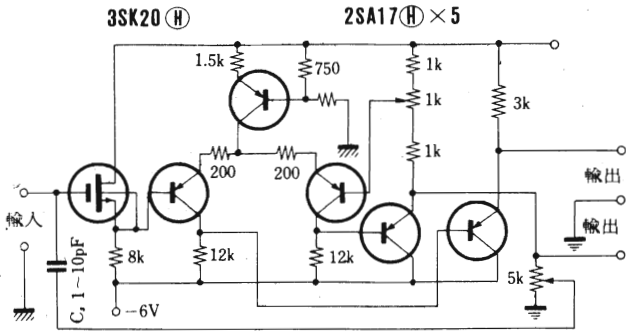

所以要採用 MOS 型的場效應管。

斷續器電路

FET 在構造上的電壓性偏移程度小，同時電流性的偏移度也非常小，所以斷續器 (Chopper) 電路多樂於使用。

因 FET 的電極間容量的存在，因而引起尖峰偏移，為着要補償偏移

的緣故，不得不在電路上加上各式各樣的補償電路。

[電路⑨] 是附有推動脈沖源 (多諧振盪電路) 的調制型斷續器，輸出與同步檢波，均使用 FET，這是使推動源的負荷減輕而已，並無其他別的優點。

為着作尖峰補償的緣故，推動脈沖源與反相的脈沖，均加接在洩極之上。

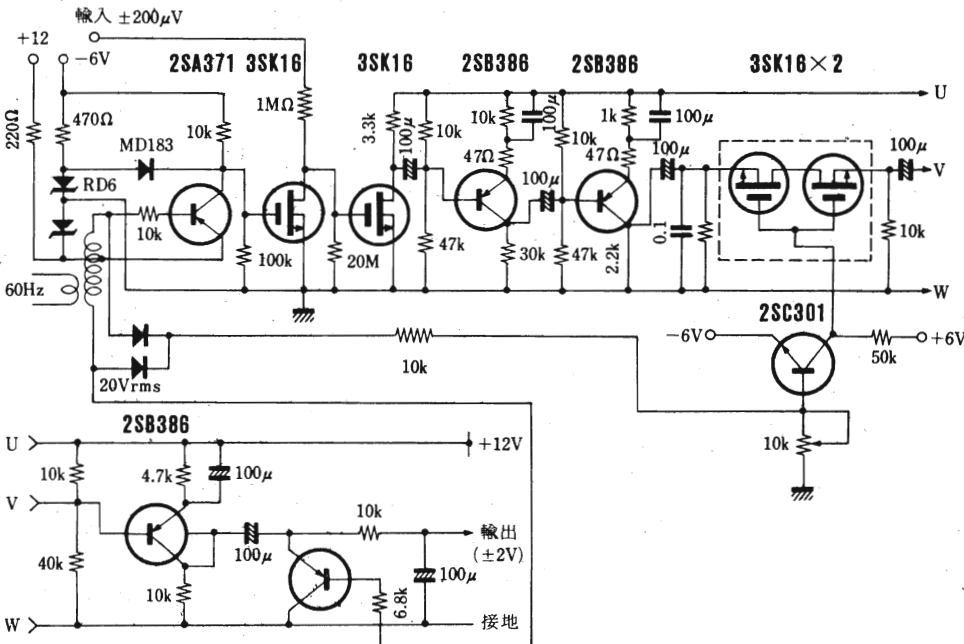
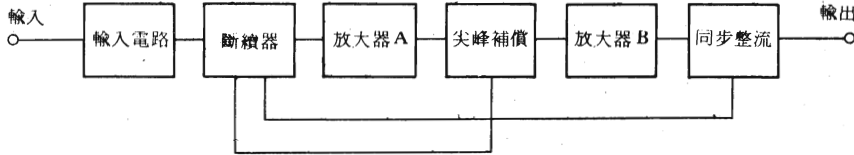

[電路⑩] MOS 斷續器 直流放大電路

[電路⑧] pH表

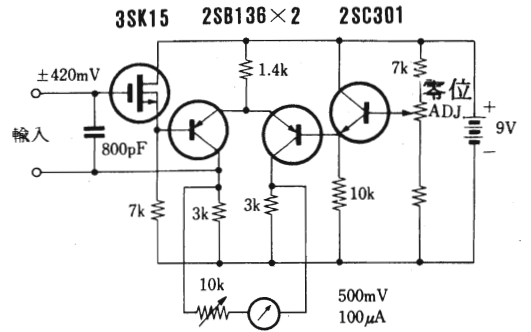

[電路⑩] 一眼看來覺得相當複雜，但是可以參考方框圖，這電路的特色，是當尖峰產生期間，利用取樣 (Sampling) 方法，使輸出等於零，這樣便可將尖峰的重疊波形作整形處理。

[電路⑪] 是使用結型 FET 的串聯式與串並聯式的斷續器電路。

高輸入阻抗電路

[電路⑨] 調制型斷續器電路

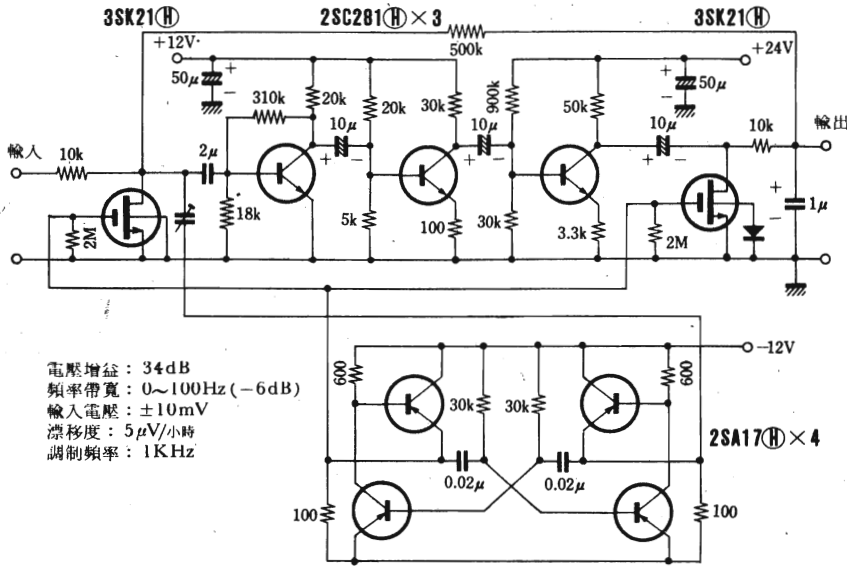

因為 MOS 的洩漏電流小，閘極的偏壓電阻雖然相當大，但是對於溫度特性上是沒有問題的；所以可作簡單的高輸入阻抗電路，如 [電路⑫] 便是這類的電路，可是如果閘極的阻抗太高的話，積聚的電荷便沒法逃出來，加上脈沖性的雜音等，便會使到工作停止，所以在用途上便受到限制。因為結型的 FET，反向電流比較大，所以偏壓電阻在大到某一個程度時，偏壓便會起變化，溫度特性變劣，所以在 [電路⑬] 的電路上閘極電阻不使用得太大，代以在源極上加正回輸，外表看來交流的阻抗增大，即是使用所謂升阻電路，可是從訊噪比 S/N 觀點看，是不利的電路，因為由串聯於閘極的高電阻所產生的熱雜

[電路⑩]

(a) 串聯式斷續器電路

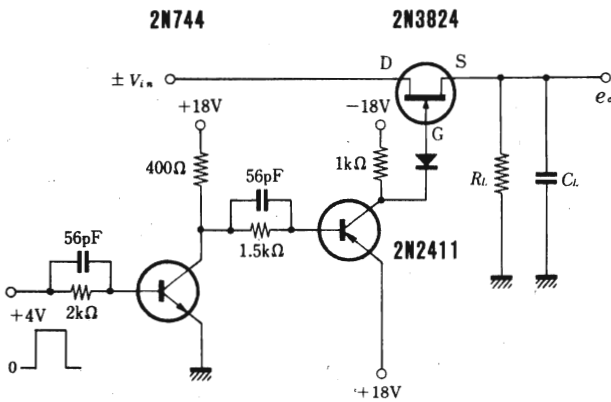

(b) 串並聯式斷續器電路

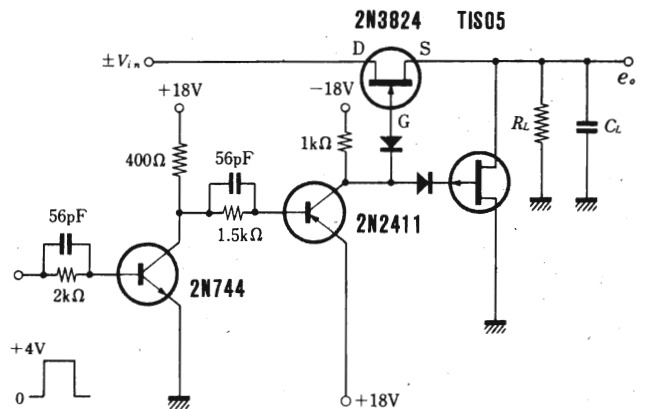

[電路⑬] 高輸入電阻雜音放大電路

- 輸入電阻
($f = 1\text{kHz}$) $80\text{M}\Omega$
 - 噪聲系數
($f = 1\text{kHz}$, $R_g = 1\text{M}\Omega$) 1dB
- 電壓增益：26dB
 開環路增益：45dB
 輸入電阻：30MΩ ($f = 1\text{kHz}$)
 噪聲系數：0.5dB ($f = 1\text{kHz}$, $R_g = 1\text{M}\Omega$)

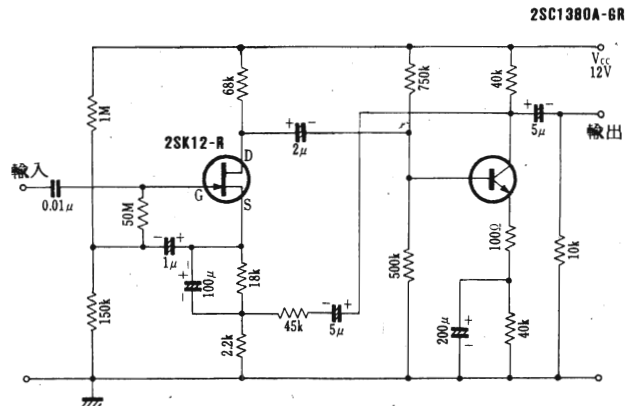

[電路⑫] 高輸入阻抗前置放大電路

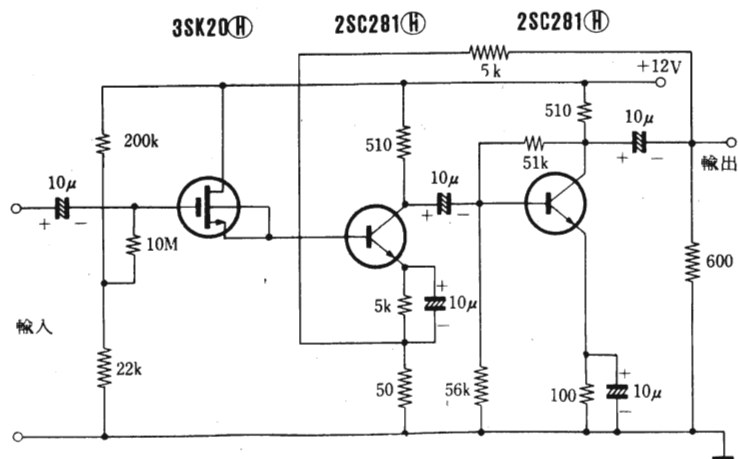

性能

- 電壓增益：40dB
- 輸出電壓：3Vmax
- 失真率：1%max (Vo = 3V)
- 頻率帶寬：20Hz ~ 500KHz (-1dB)
- 輸入阻抗：10MΩmi
- 輸出雜音電壓：1mV

音，如果沒有回輸電容器，則和輸入訊號一樣由源極的非旁路電阻作回輸，它的實效值變小，如果加上電容器，熱雜音便會加在閘極與源極間之上，S/N便會惡化。

音頻電路

因為 FET 有着高輸入阻抗，所

以有着低雜音特性的高阻抗訊號源，多採用 FET 來作為各種阻抗變換電路。例如各種阻抗變換電路（永電體微音器、電容式微音器、電容式唱頭等）、前置放大器、音量控制器、及利用 FET 的可變電阻特性的電子可變電阻電路（杜比電路、4ch 解碼器等）。還有和普通 FET 完全不同構造的縱型 FET，這種 FET 是用於

電力放大電路上，應用範圍相當廣闊，對於輸入是高阻抗的訊號源；如果使用普通晶體管的話，便要用射極輸出式電路，這樣一來便會產生低音段不足，及雜音特性不能充份的現象，所以這個寶座便要讓給 FET 了。[電路⑭] 是陶瓷壓電體唱頭用的高輸

[電路⑯] M.M., M.C. 用均衡放大電路 (2)

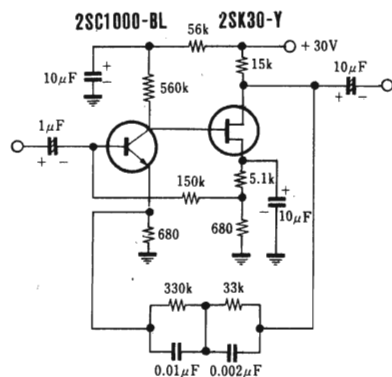

輸入阻抗 100KΩ 以上
電壓增益 40.5dB @ 1KHz
無失真的最大輸出電壓 7.0V @ 100Hz
9.5V @ 1KHz
9.0V @ 10KHz

輸出雜音電壓

輸入短路 0.09mV
4KΩ 短路 0.12mV
輸入開路 2.0mV

[電路⑭] 陶瓷唱頭用的前置放大器

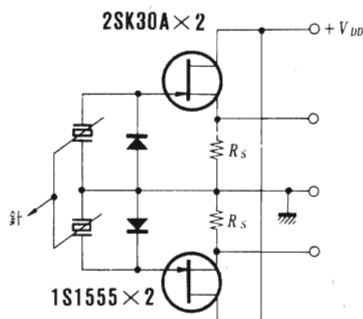

[電路⑮] MM及MC磁性唱頭用的均衡放大電路 (1)

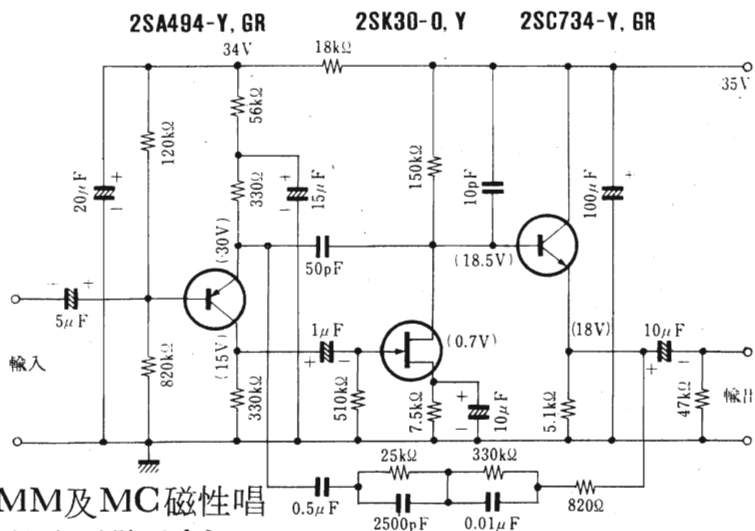

入阻抗的前置放大電路；倘若是MM（動磁式）及MC（動圈式）的低阻抗唱頭的話，使用普通晶體管會較為有利。

[電路⑮] 是普通晶體管與 FET 混合的理想電路，它的第二級用高輸入阻抗的 FET，所以初級不會受第二級影響，同時可以利用選擇最小的負回輸，使得到最適合的工作電流，而得到自由選擇負荷電阻的效果，得到充分的增益。

[電路⑰] M. M., M. C. 用均衡放大電路 (3)

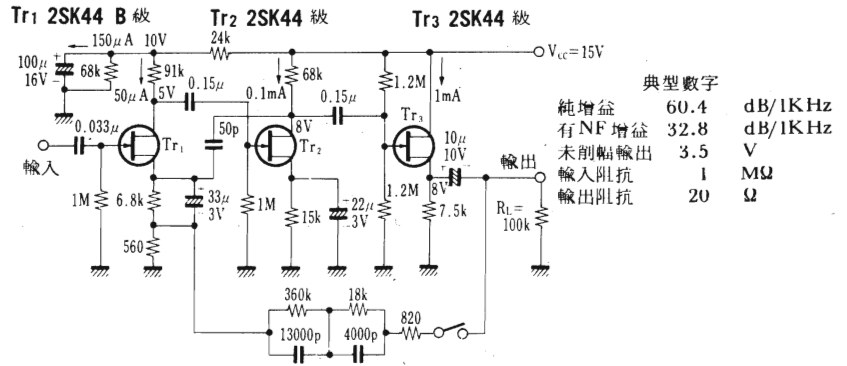

[電路⑱] CR 型音調控制電路

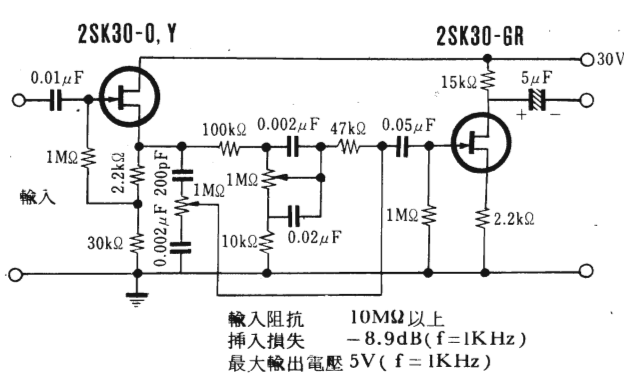

[電路⑲] 回輸型音調控制電路

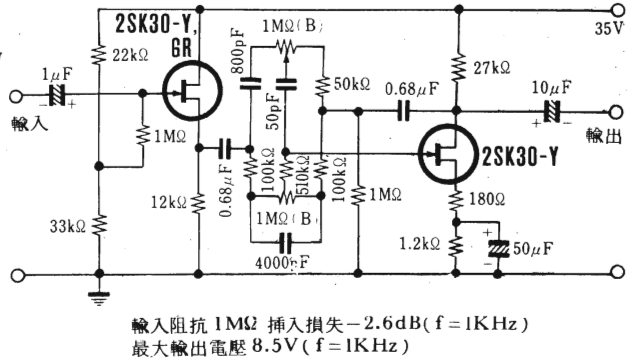

[電路⑳] 全 FET 式 50W 電力放大器

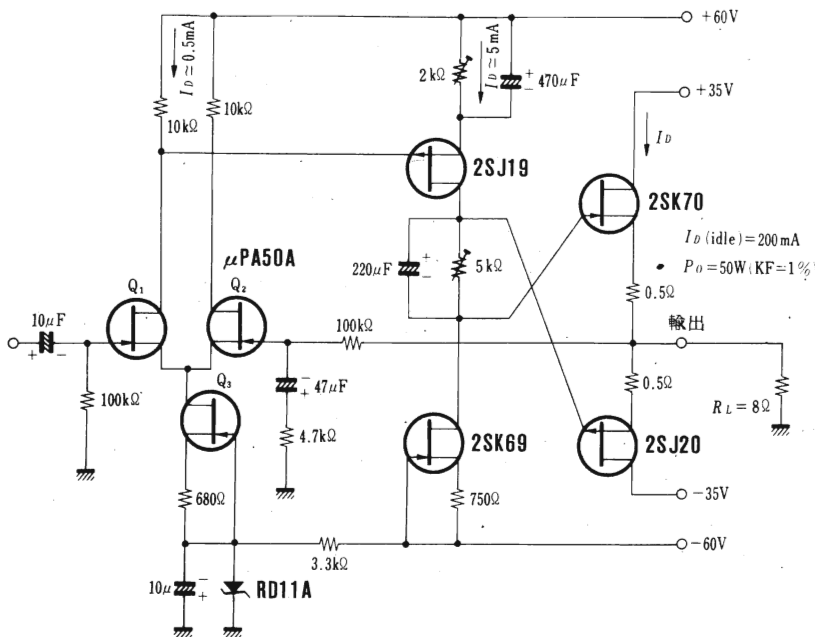

電路的 S/N 值，是由前級所決定，因為第二級是用高輸入阻抗和 NF 小的 FET，所以完全沒有問題。

[電路⑮] 是同樣用於 MM 及 MC 唱頭的電路，電路是採用兩級直接交連式。[電路⑰] 則是三級 FET 的綫路，因為 FET 有低脈沖雜音特性的關係，所以不能不用。

[電路⑱] (CR 型) 與 [電路⑲] (NF 型) 是音調控制電路圖，FET 本身是高輸入阻抗特性，特別是 CR 型電路，用普通晶體管是不能向 FET 一樣，能夠將音質控制的特色表現出來的。

最近除了電子管、晶體管外，最引人注目的是所謂第三音源。這是指用有三極管特性的縱型 FET 構成的放大器所產生的音色，這種功率上用 FET 的特徵是(一)與普通晶體管比較

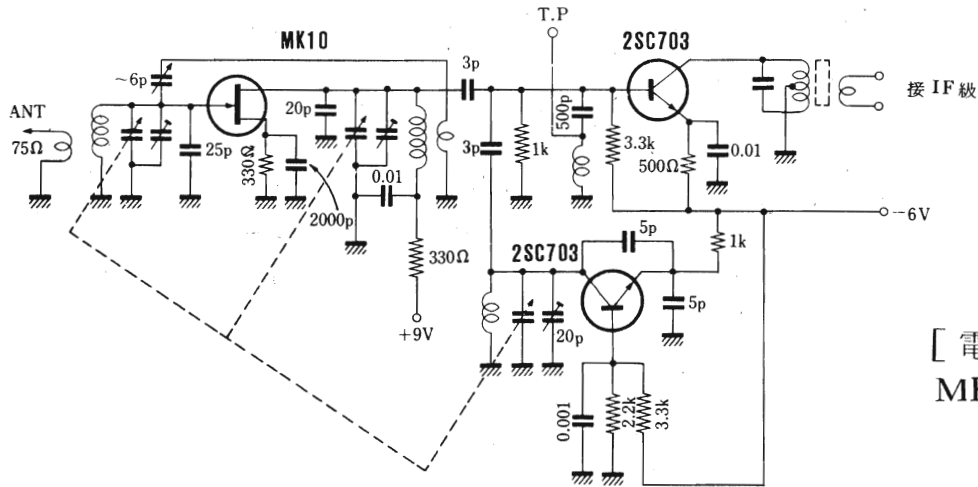

[電路⑳] 使用 MK10 的 FM 調諧器

，由第三次高諧波起，奇次數的高諧波非常小。(二)沒有少數載流子的積蓄效應、開關速度高，因此改善(三)因高音段頻率所引起的失真(採用 B 類互補式電路)，[電路⑳] 是全 FET 的 50W 功率放大器的綫路圖例子。

FM 調諧器

最近 FM 調諧器，多數採用 FET 場效應管，現在將 FET 的代表性的特性與電路介紹出來。

FET 的優點，1. 輸入阻抗高的緣故，很容易得到高輸入 Q 值，影像干擾比率優良；2. 傳導特性極近平方的特性，交擾調制特性，寄生振盪的特性優良；3. 低雜音的原故，

S/N 比得以改善。

FET 用於射頻 RF 電路時，通常採用源極接地方式，因為 FET 的源極接地方式的 $|Y_f/Y_r|$ 小，增益會較大，很容易產生振盪，所以要特別留意。

[電路㉑] 是 FM 調諧器的圖例，它

[電路㉑] 使用 2SK41 的 FM 調諧器

	(88MHz)	(98MHz)	(108MHz)
調諧電力增益	29.0dB	29.2dB	28.2dB
回輸量	4.7dB	4.5dB	4.5dB
影像干擾比	54.7dB	49.5dB	47.2dB
中頻干擾比	80dB 以上		
AGC 特性	見另圖		
消耗電流	9.6mA		
輸入阻抗	300Ω 平衡		
輸出	300Ω		

零件數據

- 天綫綫圈 L1 :
 - ①-③ 1 3/4 T, 0.6φ 綫用 4.5φ 綫圈筒
 - ④-⑤ 3 3/4 T, 0.6φ 綫用 4.5φ 綫圈筒
 - ⑤-⑥ 1 1/8 T, 0.6φ 綫用 4.5φ 綫圈筒
 - ④-⑥ 間之 Qo > 120
- RF 綫圈 L2 :
 - ③-② 3 3/4 T, 0.6φ 綫用 4.5φ 綫圈筒
 - ③-① 1/2 T, 0.6φ 綫用 4.5φ 綫圈筒
 - ②-③ 間之 Qo > 100
- IF 陷波綫圈 L3 :

Qo > 80 採用如右圖之中頻變壓器用鐵芯，0.26φ 綫 19T
- 振盪綫圈 L4 :
 - ①-② 2 1/4 T, 0.6φ 綫用 4.5φ 綫圈筒
- IFT L5 :
 - ①-② : ③-④ = 7T : 1T
 - 200pF 同調
 - 0.12φ 漆皮綫，Qo = 80
- 可變電容器

Alps 廠之 B515D

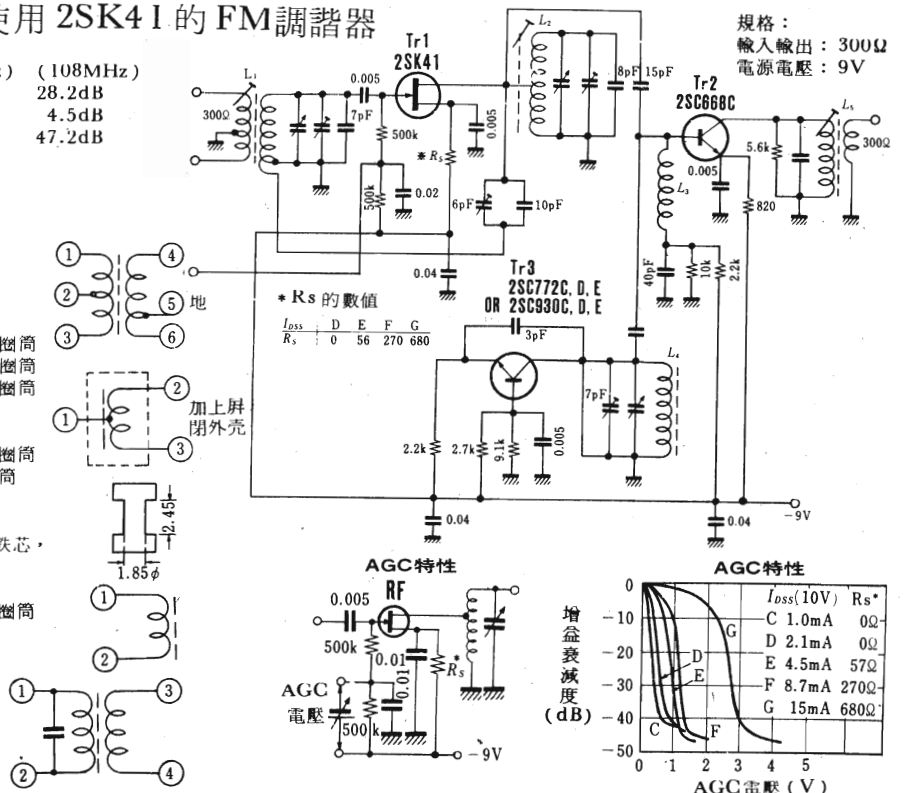

規格：
輸入輸出：300Ω
電源電壓：9V

* Rs 的數值

I _{loss}	D	E	F	G
R _s	0	56	270	680

AGC 特性

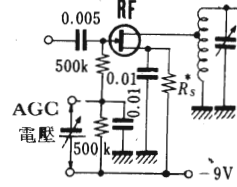

AGC 特性

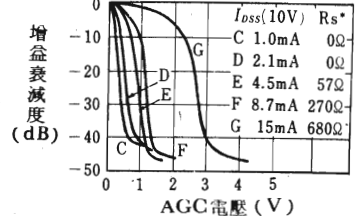

[電路⑳] NF 試測用前級放大器

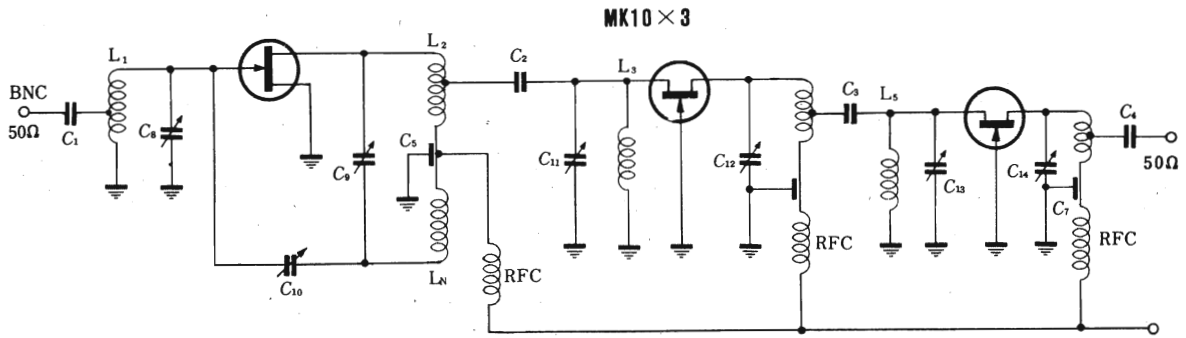

- C₁ ~ C₄ 0.01μF
- C₅ ~ C₇ 2000pF
- C₈ · C_N 50pF max
- C₁₀ 3pF max
- C₉ · C₁₂ ~ C₁₄ 20pF max

繞圈數	繞圈直徑	線徑	間格	圈數	圈數比
L ₁	10mm	1mm	2 mm	4	20/1
L ₂	"	"	"	"	1/2
L ₃	"	"	"	"	1
L ₄	"	"	"	5	1
L ₅	"	"	"	4	1
L ₆	"	"	"	5	1/15
L _N	"	"	"	4	1

[電路㉑]
FET VHF
調諧電路

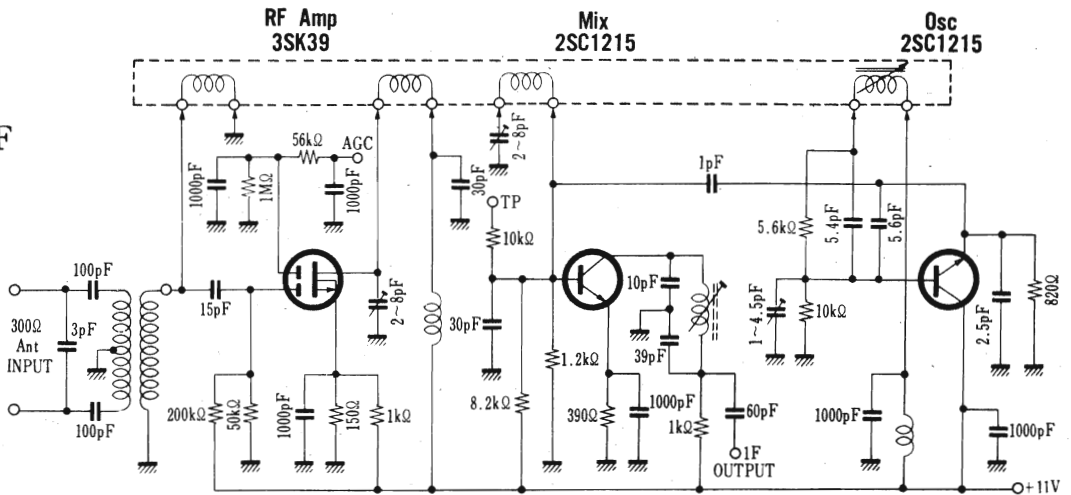

[電路㉓] 文氏電橋振盪電路

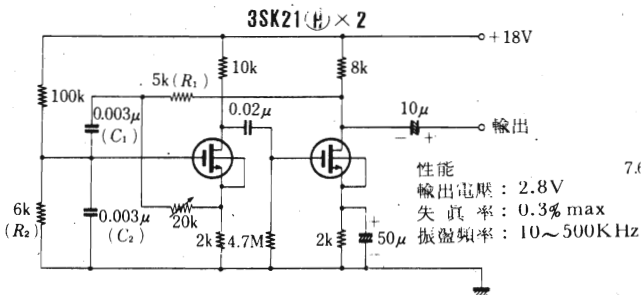

[電路㉔] 7.63MHz 石英晶體振盪電路

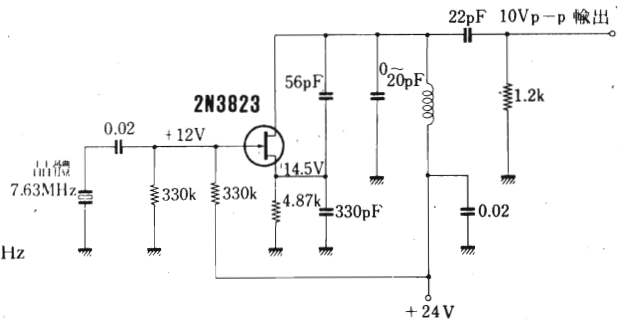

[電路⑳] 時間掣電路 (結型 FET) [電路㉑] 使用 2SK21 的時間電路 (MOS)

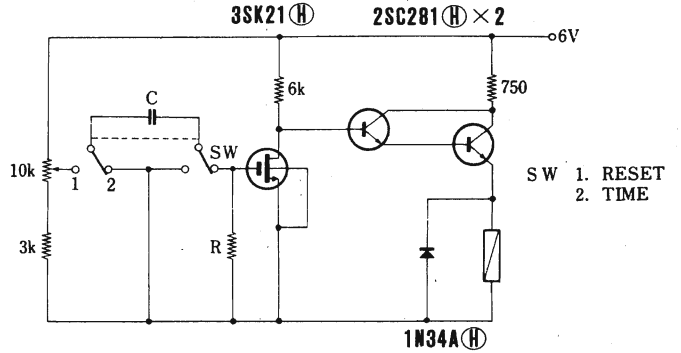
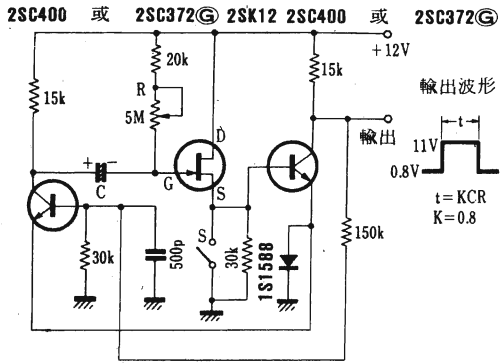

由短路端起 45.7mm 處抽頭；

Lo: 6.35mm φ, 全長 78.8mm

[電路㉑] 是利用 FET 的 UHF 混頻電路。

振盪電路

因為 FET 的輸入阻抗, 是不像普通晶體管的受限制, 所以能夠使用, 跟電子管一樣的電路, 同時對於振盪頻率的初期溫度漂移特性, 是較電子管的優良, 於是各色各樣的振盪電路

, 均採用 FET。

[電路㉑] 是 CR 相移振盪電路圖, 採用四級移相式, 它的中心頻率可用下式計算:

$$f_o = 0.133/CR,$$

故這綫路的中心頻率, 計算出來是, $f_o = 11\text{Hz}$, 圖中的可變電阻, 是作微調之用。

[電路㉑] 是採用 MOS 型的文氏電橋式振盪電路, 它的計算公式如下:

$$f_o = \frac{1}{2\pi \sqrt{C_1 C_2 R_1 R_2}}$$

故這綫路的中心頻率是 10KHz。

[電路㉑] 是晶體振盪電路圖。

開關電路

[電路㉑] 是觸發器電路。FET 的開關時間, 比較慢, 因此高速開關電路是不採用 FET。

[電路㉑] 是一種單穩態振盪電路, 可以得到較長的延遲時間。

[電路㉑] 是利用單穩態振盪電路作時間掣。

[電路㉑] 則是採用 MOS 型的 FET 作時間掣的電路。

MOS 型的 FET, 比較普通晶體管較為有利的地方, 是製作簡單, 不需要絕緣, 可以當電阻用, 如果製成 IC 時, 成本大大地降低, 還有用 MOS 的 IC 作邏輯電路時, 使用增強型的 MOS, 它的優點是, 開啓電壓大, 減小雜音方面的干擾, 動作安定。

[電路㉑] 是 P 通道與 N 通道組成的補償式變換電路。

[電路㉑] 互補型變換電路

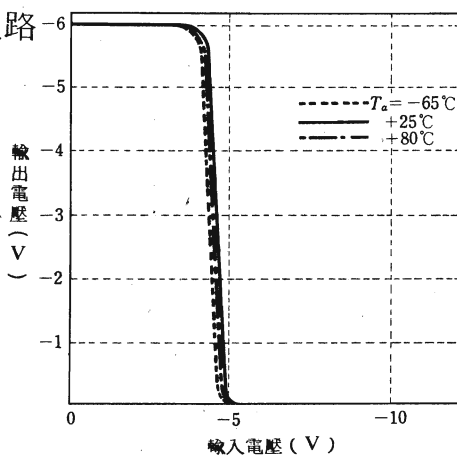
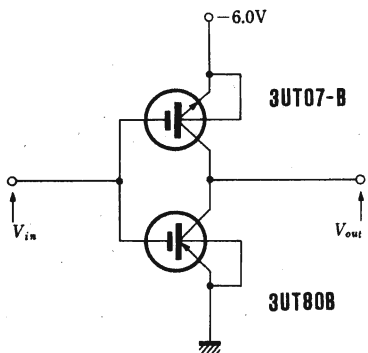



**SUPPLEMENT TO SECTION 1:
TERMINATION DRAWINGS**

晶體管特性補充
與外形接腳圖

型名	社名	用途	構造	最大定格 (T _a = 25°C)					電 氣 的 特 性 (T _a = 25°C)											外 形	備 考			
				V _{CB0} (V)	V _{EB0} (V)	I _C (mA)	P _C (mW)	T _J (°C)	I _{CB0} 最大值 (μA)	V _{CB(V)}	直流及脉冲下之h _{FE}		偏置情况		h _{FE} *	h _{FE} *	h _{FE} *	h _{FE} *	f _{os} f _T *			C _{os}	r _{os} h _{ic(roll)} *	
										V _{CE(V)}	I _{C(mA)}	V _{CB(V)}	I _{E(mA)}	h _{FE} *	h _{FE} *	h _{FE} *	h _{FE} *	(Mc)	(pF)	(Ω)				
2SA119	富士通	RF.PA	Si.EP	-40		-300	650	175	-0.1	-10				-10	10	60				200*	4.5	50*	84B	
" 120	"	"	"	-25		-300	650	175	-1	-10				-10	10	60				200*	4.5	50*	84B	
" 142A	三菱	RF	Ge.A	-40	-1.5	-15	80	85	-5	-12				-6	1	70				8	11	60	12A	
" 217	日立			-25	-12	-100	120	85	-1	-12	30-120	-0.3	-100							14	20	200*	50C	
" 431A	东芝	RF	Ge.Me	-20		-5	70	85	-10	-12				-6	1	-0.95							50C	
" 432A	"	"	"	-20	-0.2	-5	70	85	-10	-12				-6	1	-0.95							50C	
" 440A	三洋	RF.Conv. Mix.Osc	"	-20	-0.4	-5	60	85	-30	-2				-6	2	50							48C	
" 549A	日立	SW	Si.EP	-110	-5	-100	200	175	-1	-20	30-200	-1	-10										182C	
" 628A	三菱	RF.AF.SW	"	-60	-4	-100	150	125	-0.1	-25	200	-6	-1	-6	1		6500	0.3	14	100*	3.5	C _{os} 100pS	138B	再登録
" 673A	日立	RF	"	-50	-4	-500	400	125	-0.5	-20	130	-3	-10	-6	1					50*	7	12*	170	25C1213A 之對稱
" 699A	松下	PA	"	-50	-5	-2A	10W (T _c =25°C)	150	-1	-20	120	-5	-1A	-5	500					150*	50	3.3*	161	25C1226A 之對稱
" 708A	日電	RF	Si.E	-100	-8	-700	800	150	-0.1	-60	140	-2	-50	-10	50					50*	25	25*	84B	
" 713A	"	"	Si.E シリコン	-40	-10	-300	250	125	-0.1	-20	30,000	-5	-100	-10	10					180*	6	200*	138	
" 728A	三菱	RF.AF	Si.EP	-60	-5	-100	100	125	-0.1	-25	200	-6	-10	-6	1		6500	0.3	14	100*	3.5	C _{os} 100pS	175	
" 774A	松下	RF.LN	"	-55	-5	-50	150	175	-0.1	-10	540	-5	-2	-5	2		3500	3	60	120*	5	100	54	
" 776A	东芝	"	"	-55	-5	-50	200	150	-0.1	-30	300	-6	-2	-6	1	285	7300	1	21	180*	3	35	195	
" 778A	日立	RF	Si.T	-180	-5	-50	200 (T _c =25°C)	125	-1	-150	80	-3	-15	-10	10					60*	4	C _{os} 40pS	170	
" 780A	"	"	Si.P	-80	-4	-1A	10W (T _c =25°C)	150	-1	-80	120	-4	-50	-4	50					120*	8	50*	234	
2SA745A	SAK	PA	Si.EMe	-120	-6	-8A	70W (T _c =25°C)	150	-1mA	-120	60	-4	-3A	-12	500					15*	220	10*	102	
" 747A	"	"	"	-140	-6	-10A	100W (T _c =25°C)	150	-1mA	-140	60	-4	-3A	-12	500					15*	255	10*	102	
2SA666A	松下	RF.AF.LN	Si.EP	-45	-5	-50	150	125	-1	-10	250	-5	-2										138	
" 699A	"	PA	"	-50	-5	-2A	10W (T _c =25°C)	150	-1	-20	120	-5	-1A	-5	500					150*			161	
" 740A	东芝	RF.PA	Si.TMe	-150	-5	-1.5A	25W (T _c =25°C)	150	-10	-100	75	-10	-500	-10	500					5*	55	25	268	
" 743A	日立	RF.PA	Si.E	-80	-4	-1A	8W (T _c =25°C)	150	-1mA	-80	120	-4	-50	-4	30					120*	30	4*	160	25C1212A 之對稱
2SB67A	日立	AF	Ge.A	-60	-30	150	300 (T _c =25°C)	70								50-175							66	
" 136A	三菱	PA	"	-60	-12	-300	150	85	-10	-25	120	-1.5	-50										12B	
" 216A	三洋	"	"	-60	-10	-3A	24W (T _c =25°C)	85	-500	-20	80	-1.5	-1A					0.5					102	
" 426A	东芝	"	"	-45	-12	-3A	30W (T _c =25°C)	85	-160	-12	60	-1.5	-1A										102	
" 452A	三菱	"	"	-45	-6	-1A	300	85	-30	-12	150	-1	-150										69	
" 495A	"	"	"	-32	-6	-1A	200	85	-20	-12	110	-1	-150										12A	
" 512A	松下	"	Si.EMe	-80	-8	-3A	25W (T _c =25°C)	150	-30	-20	60	-3	-1A										178	
" 513A	"	"	"	-80	-8	-3A	25W (T _c =25°C)	150	-30	-20	60	-3	-1A										179	
2SB504A	日電	PA.SW	Si.EP	-100	-10	-2A	1W	175	-1	-80	80	-2	-500										84B	
" 506A	"	"	"	-150	-7	-5A	60W (T _c =25°C)	175	-2mA	-150	70	-5	-1A										102	
2SB57A	富士通	SW	Ge.A	-45	-15	-500	225	85	-15	-45	70	-1	-50	-6	-1	0.985*	30*	3*	0.3*	2		t _r < 2μS, t _{fall} < 2μS t _f < 2μS	84B	
" 126A	松下	SW	Ge.A	-60	-10	-3.5A	40W (T _c =45°C)	90	-200	-14	35	-1	-1A										102	
" 127A	"	"	"	-60	-10	-3.5A	40W (T _c =45°C)	90	-200	-14	75	-1	-1A										102	
" 207A	新電元	PA	Ge.A	-140	-20	-20A	80	85	-5mA	-140	40	-1.5	-15A	-6	-2						f _{os} 2.5kc		105	
" 208A	"	"	"	-140	-20	-30A	80	85	-5mA	-140	100	-1.5	-15A	-6	-2						f _{os} 2.5kc		105	
" 213A	"	SW	"	-140	-40	-20A	80	85	-5mA	-140	40	-1.5	-15A	-6	-2						f _{os} 2.5kc		105	
" 214A	"	"	"	-140	-40	-30A	80	85	-5mA	-140	100	-1.5	-15A	-6	-2						f _{os} 2.5kc		105	
" 539A	日電	PA	Si.TMe	-130	-6	-10A	100W (T _c =25°C)	150	-100	-120	80	-5	-2A										102	
" 539B	"	"	"	-140	-6	-10A	100W (T _c =25°C)	150	-100	-120	80	-5	-2A										102	

型名	社名	用途	構造	最大定格 (T _a = 25°C)						電 氣 的 特 性 (T _a = 25°C)											外 形	備 考					
				V _{CB0} (V)	V _{EBO} (V)	I _C (mA)	P _C (mW)	T _J (°C)	I _{CB0} 最大値		直流及脉冲下之 h _{FE}		偏置情况		h _{FE} *	h _{FE} h _{FE} * (Ω)	h _{FE} h _{FE} * (×10 ⁻⁴)	h _{FE} h _{FE} * (μU)	f _{os} f _T * (Mc)	C _{os} (pF)			r _{os} h _{os} (real)* (Ω)				
									(μA)	V _{CB} (V)	I _C (mA)	V _{CE} (V)	I _C (mA)	V _{CB} (V)										I _E (mA)	h _{FE} *	h _{FE} * (Ω)	h _{FE} * (×10 ⁻⁴)
2SC89	日立	SW	Ge. A	25	20	400	120	85	8	12	20-100	-0.2	20											73A			
* 90	"	"	"	25	20	400	120	85	8	12	20-120	-0.3	200											73A			
* 91	"	"	"	25	20	400	120	85	8	12	30-200	-0.3	200											73A			
* 97A	日電	RF. SW	Si. EP	80	5	1 A	800	175	0.5	45	80	10	50	10	-50	t _{os} < 70nS t _{os} < 30nS, t _{off} < 90nS	350*	6	30				84C				
* 101A	東芝	RF	Si. TMe	70	5	5 A	30W (T _a =25°C)	150	1mA	50				10	±0.5A	30				20*	150	15		101			
* 108A	"	RF. SW	Si. EP	90	5	800	800	175	1	30	80	2	200	10	-10	t _{os} < 0.15μS, t _{os} < 0.15μS t _{os} < 0.15μS	20*	55	55					84B			
* 109A	"	"	"	50	5	800	800	150	1	15	80	2	200	10	-10	"	20*	55	55					84B			
* 154B	日立	RF	Si. TPa	150	5	100	750	175	10	180	50	10	10	10	-10	60	220*	2.5	70*					84C			
* 154C	"	"	"	200	6	100	750	175	0.1	100	90	10	25	10	-10	60	150*	2.5	15*					84C			
* 168	沖	RF. SW	Si. EP	20	5	200	250	175	0.1	15	85	1	10	10	-10	110	t _{os} < 50nS, t _{off} < 60nS t _{os} < 40nS	400*	4	70*					49C		
* 169	"	"	"	40	5	200	250	175	0.1	15	85	1	10	10	-10	110	t _{os} < 40nS, t _{off} < 44nS t _{os} < 26nS	450*	4	70*					49C		
* 183A	日電	RF. V	"	30	5	30	100	150	0.1	25	75	3	0.5	6	-1	80	3000	0.5	6.5	160*	1.8	45			23		
* 193A	富士通	PA	"	50	5	500	800	175	1	10				10	-20	40				350*	6	50*			85B		
* 219	"	RF	Si. P	20	5	25	200	175	0.02	12				60		60				600*	1.3				50C		
* 268A	日電	RF. PA. SW	"	80	5	30	150	150	3	50				6	-1	55				150*	1.6	50			23		
* 268B	"	RF. SW	Si. EP	150	5	30	150	150	0.1	100	120	1	1	6	-1					75*	2.8	25*			139		
* 287A	"	RF. Conv. Mix. Osc.	Si. P	35	4	20	150	150	0.2	15				10	-5	80				1100*	0.7	C _{os} F _{os} 10pS			23		
* 288A	"	"	Si. EP	35	2	20	150	150	1	15				10	-5	80				1100*	0.7	C _{os} F _{os} 10pS			23		
* 317A	日立	SW	Si. EMe	100	5	100	350	175	0.1	20	100	6	10	6	-10	t _{os} < 0.08μS, t _{os} < 0.2μS t _{os} < 0.7μS	180*	4.5	75						12A		
* 318A	SON	RF. SW	Si. PaMe	50	5	100	300	175	0.2	25	90	3	1	6	-1	120	h _{FE} = 4.5dB (f = 100MHz)			3					49C		
* 352A	"	"	"	50	5	100	750	175	0.2	25	90	3	1	6	-1	120	h _{FE} = 3dB (f = 100MHz)			3					84B		
* 353A	"	"	"	100	5	100	750	175	0.2	25	90	3	1	6	-1					3					84B		
* 380A	東芝	IF	Si. P	35	4	30	200	125	0.5	18	40-240	12	2	10	-1					250*	2	20			33		
* 385A	"	OSC	Si. EP	30	3	20	200	125	0.5	15	>20	3	8	10	-8		h _{FE} > 6dB (f = 100MHz)								<1.5	<35	33
* 386A	"	"	"	20	3	20	200	125	0.5	15	40	3	8	10	-8		h _{FE} = 6.0dB (f = 100MHz)								1:2	18	33
* 387A	"	RF. Conv. Mix. Osc.	"	30	3	50	200	125	0.5	15	>20	3	8	10	-8					1200*	<1.5	<25			33		
* 388A	"	OSC	"	25	3	50	300	125	0.025	10	20-200	12.5	12.5	12.5	12.5					>300*	0.8-2.8	<25			33		
* 395A	"	SW	"	20	5	500	300	175	0.1	20	30-200	1	10	10	-10	t _{os} < 40nS, t _{os} < 30nS t _{os} < 50nS	400*	4							49C		
* 402A	SON	RF. Conv. Mix. Osc.	Si. E	50		100	180	120	0.2	25	90	3	1	6	-1	110				140*	2.5				38		
* 403A	"	"	"	50		100	180	120	0.2	25	60	3	1	6	-1	75				140*	2.2				38		
2SC410A	新電元	SW	Si. DB	200	4	10 A	100W (T _a =25°C)	150	20mA	200	37	5	5 A	10	2 A	t _{os} < 1.2μS, t _{os} < 5μS t _{os} < 4μS	f _{os} 0.4									102	
* 434A	"	"	"	200	4	30 A	100W (T _a =25°C)	150	20mA	200	28	5	10 A	10	2 A	"	f _{os} 0.4									105	
* 487A	東芝	PA	Si. P	150	5	1.5 A	15W (T _a =25°C)	150	1mA	30	100	2	200	10	-50					20*	85	5				99	
* 642A	"	"	Si. TMe	1500	5	1 A	50W (T _a =25°C)	150	10	500	30-160	15	150	15	-200					>0.5	70	10				102	
* 643A	"	"	"	1500	5	2.5 A	50W (T _a =25°C)	150	10	500	>5	15	2 A	15	-200					>2	80	10				102	
* 680A	日立	"	Si. T	200	6	2 A	12.5W (T _a =25°C)	150	1	30	180	10	200													153	
* 681A	"	"	"	250	5	6 A	50W (T _a =25°C)	150	I _{CB0} 15mA	30																102	
* 685A	"	"	Si. TPa	300	4	100	6.5W (T _a =25°C)	150			60	10	50													153	
* 711A	三菱	RF. AF. SW	Si. EP	50	4	100	200	125	0.1	25	250	6	1	6	-1		8500	0.6	40	150*	2.5	C _{os} F _{os} 200pS			138	再登録	
* 782A	東芝	PA	Si. TP	300	5	1.5 A	25W (T _a =25°C)	150	30	300	150	10	100	10	-100					10*	70	25			99		
* 914A	富士通, 沖, 日立	SW	Si. EP	40	5	300	300	175	0.2	20	70	1	30			h _{FE} > 14 (2V, 300mA)	t _{os} < 80nS, t _{os} < 86nS t _{os} < 65nS									49C	
* 915A	"	"	"	30	5	300	300	175	0.2	20	70	1	30			h _{FE} > 15 (2V, 200mA)	t _{os} < 45nS, t _{os} < 42nS t _{os} < 27nS									49C	
* 926A	SON	RF. AF. SW	Si. DB	210	5	30	250	120			100	3	1	10	-10		4500	0.47	4.8	160*	2.5	C _{os} F _{os} 40pS			168		
* 936A	日立	PA	Si. TMe	1000	5	1 A	22W (T _a =25°C)	150	10	500	45	10	100	15	-200					7*	35	25			102		
* 985A	日電	RF. LN	Si. EP	20	3	40	300	200	0.1	10	100	10	15	10	-15		NF = 4dB (10V, -4mA, 2GHz)	PG = 9.5dB (2GHz)			300*	0.6	20*			26	
* 987A	"	"	"	20	3	30	250	200	0.1	10	100	10	10	10	-10		NF = 3dB (10V, -4mA, 2GHz)	PG = 11dB (2GHz)			4500*	0.5	20*			26	
* 988A	"	RF	"	20	3	30	200	200	0.1	10	80	10	10	10	-10		NF = 1.8dB (10V, -3mA, 500MHz)			3000*	0.5	30*			50C		
* 988B	"	"	"	20	3	30	200	200	0.1	10	80	10	10	10	-10		NF = 1.3dB (10V, -3mA, 500MHz)			3000*	0.5	30*			50C		
* 999A	東芝	RF. PA. SW	Si. TMe	1500	5	2.5 A	50W (T _a =25°C)	150	10	500	30	15	200	15	-200					4	80	10			102		
* 1005A	"	PA	"	1400	5	5 A	50W (T _a =25°C)	150	10	500	12	15	4 A	15	-500					3*	150	5			102		
* 1012A	松下	RF. AF. SW	Si. TP	250	5	60	2.5W (T _a =25°C)	175	2	12	60	20	40	10	-3	35	300	0.4	2.7	100*	3.5	C _{os} F _{os} 60pS			84B		
* 1122A	東芝	PA	Si. EP	35	4	4.5 A	30W (T _a =25°C)	175	50	15	40	5	1.5 A														

型名	社名	用途	構造	最大定格 (T _a = 25°C)					電氣的特性 (T _a = 25°C)										外形	備考		
				V _{CEO} (V)	V _{EB0} (V)	I _c (mA)	P _c (mW)	T _j (°C)	I _{CEO} 最大值 (μA)	V _{CE} (V)	電流及脉冲下之h _{FE}		偏置情况		h _{FE}	h _{FE} *	h _{FE} *	h _{FE} *			f _β (MHz)	C _{ob} (pF)
										V _{CE} (V)	I _C (mA)	V _{CE} (V)	I _E (mA)	h _{FE} *	h _{FE} *	h _{FE} *	h _{FE} *					
2SD51A	SON	PA	Si.Me	150	6	5 A	50 W (T _c =25°C)	150	100	50	60	3	2 A	10	-500				10*			102
* 88A	"	"	Si.TMe	100	8	10 A	120 W (T _c =25°C)	150	100	50	150	3	2 A									102
* 170A	日立	"	Ge.A	32	12	500	200	85	20	12	150	1	150									12A
* 206A	新電元	PA.SW	Si.DJ	50	8	10 A	150 W (T _c =25°C)	150	1	30	20	5	5 A	10	1 A					f _β = 18kHz		102
* 207A	"	"	"	100	8	10 A	150 W (T _c =25°C)	150	1	30	20	5	5 A	10	1 A					f _β = 18kHz		102
* 208A	"	"	"	150	8	10 A	150 W (T _c =25°C)	150	1	30	20	5	5 A	10	1 A					f _β = 18kHz		102
* 226A	松下	PA	"	60	8	3 A	25 W (T _c =25°C)	150	30	20	50	3	1 A							f _β = 25kHz		99
* 226B	"	"	"	80	8	3 A	25 W (T _c =25°C)	150	30	20	50	3	1 A							f _β = 25kHz		99
* 232A	富士通	SW.AF	Si.TMe	160	7	30 A	125 W (T _c =25°C)	175	1mA	50	25	4'	10A									102
* 317A	松下	PA	Si.T	80	8	3 A	25 W (T _c =25°C)	150	30	20	60	3	1 A	10	-200					f _β = 25kHz		155
* 318A	"	"	"	80	8	3 A	25 W (T _c =25°C)	150	30	20	60	3	1 A	10	-200					f _β = 25kHz		156
* 334A	"	"	Si.DJ	130	7	6 A	75 W (T _c =25°C)	150	1mA	130	100	4	1 A									102
* 363A	日電	SW	Si.TMe	350	6	30 A	200 W (T _c =25°C)	175	100	300	30	5	15A							t _{on} < 2μS, t _{off} < 6.5μS, t _{rise} < 4μS		106
* 365A	松下	PA	"	80	5	3 A	25 W (T _c =25°C)	150	30	20	70	3	1 A							f _β = 70kHz		178
* 366A	"	"	"	80	5	3 A	25 W (T _c =25°C)	150	30	20	70	3	1 A							f _β = 70kHz		179
* 373A	日電	SW	"	350	6	30 A	200 W (T _c =25°C)	175	100	300	30	5	15A									106
* 389A	松下	PA	Si.DJ	80	8	3 A	25 W (T _c =25°C)	150	30	20	70	3	1 A	10	-200					f _β = 25kHz		178
* 390A	"	"	"	80	8	3 A	25 W (T _c =25°C)	150	30	20	70	3	1 A	10	-200					f _β = 25kHz		179
2SD78A	日電	PA.SW	Si.EP ₄	100	12	2 A	1 W (T _c =25°C)	175	1	80	80	2	500	10	-200							84B
* 181A	"	"	Si.TMe	250	7	10 A	100 W (T _c =25°C)	175	1mA	200	60	5	5 A	10	-200							102
* 200A	松下	SW	Si.Me	1500	5	2.5 A	10 W (T _c =25°C)	115	1mA	1500	2.5	5	2 A							t _f = 0.7μS		102
* 287A	日電	PA	Si.TMe	200	7	10 A	100 W (T _c =25°C)	150	100	120	80	5	2 A									102
* 287B	"	"	"	200	7	10 A	100 W (T _c =25°C)	150	100	120	80	5	2 A									102
* 376A	"	PA.SW	"	300	7	10 A	100 W (T _c =25°C)	175	100	300	50	5	2 A							t _{on} < 1.5μS, t _{off} < 5μS, t _{rise} < 3.5μS		102

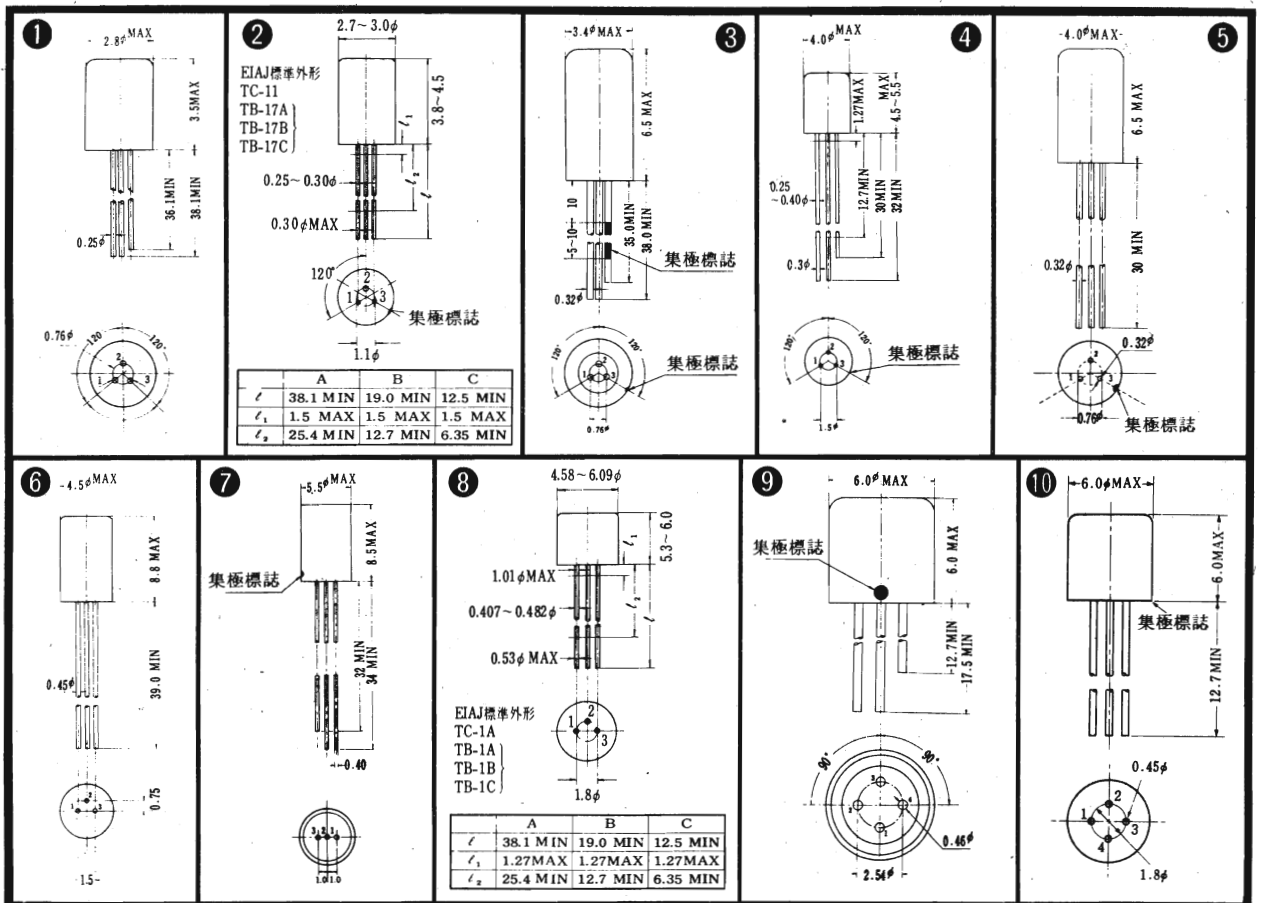

• 管脚接法無註明時，為①射極、②基極、③集極、④屏蔽電極。

◀ 尺寸圖單位：mm ▶

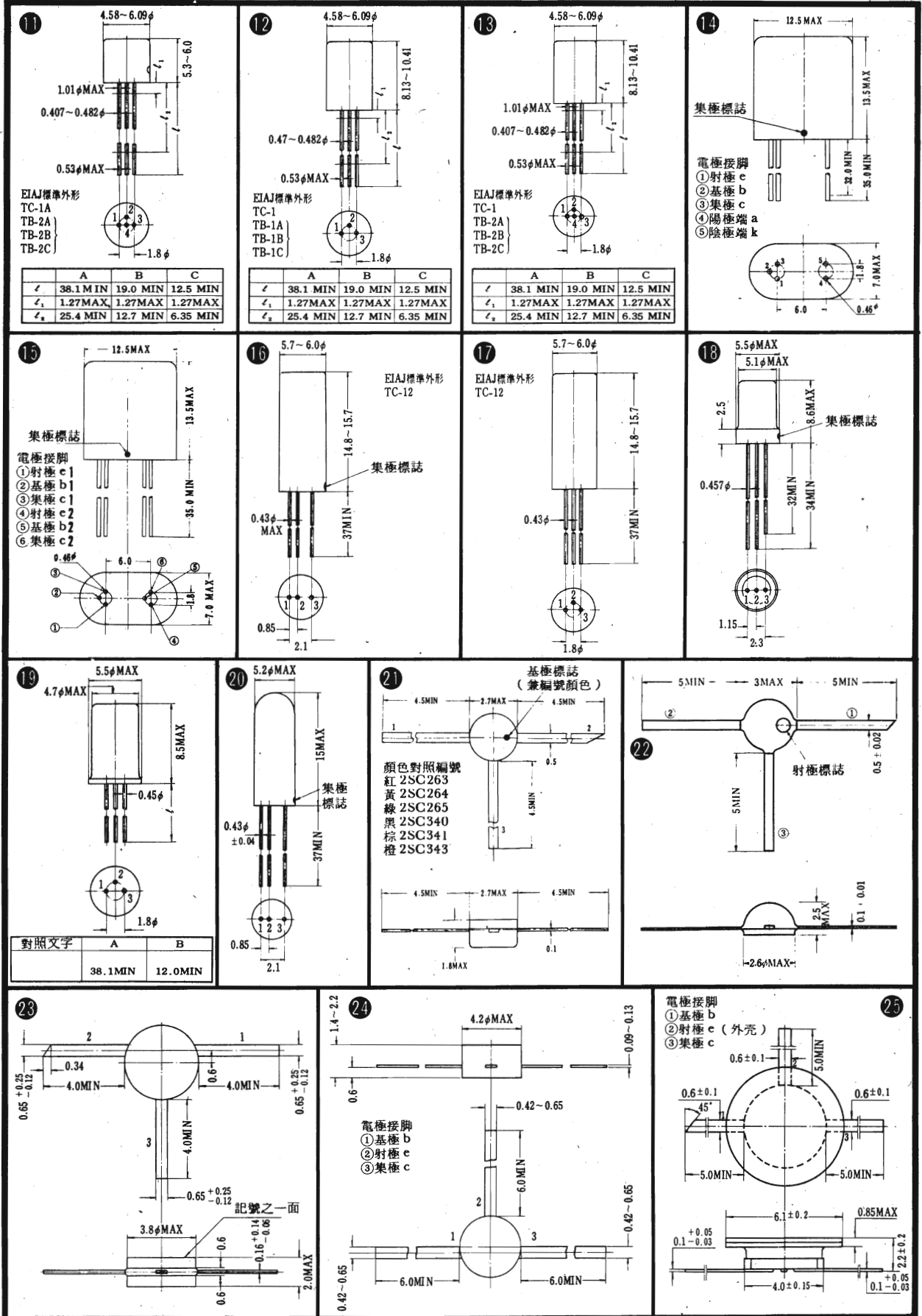

• 管腳接法無註明時，為①射極、②基極、③集極、④屏蔽電極。

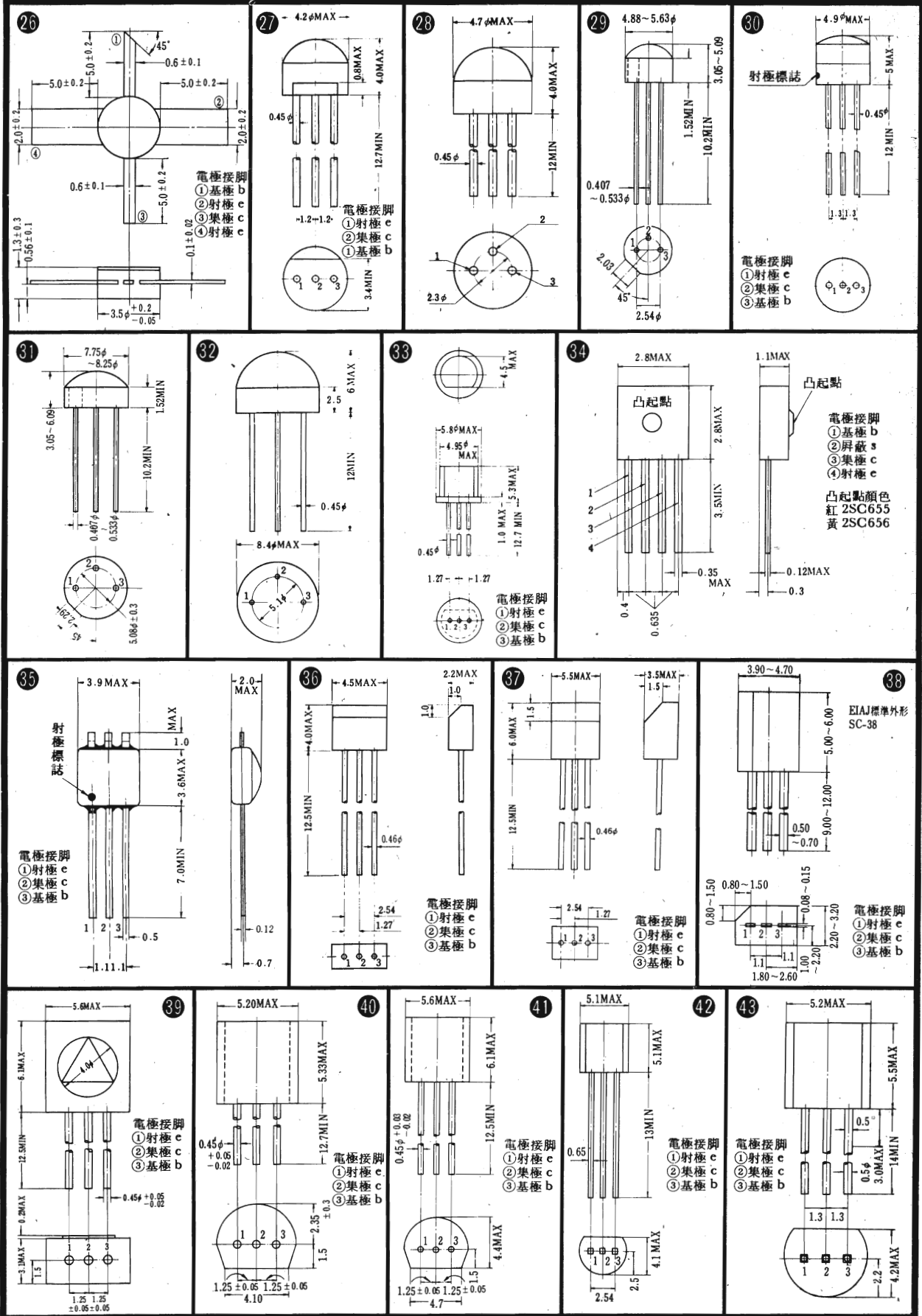

• 管脚接法無註明時，為①射極、②基極、③集極、④屏蔽電極。

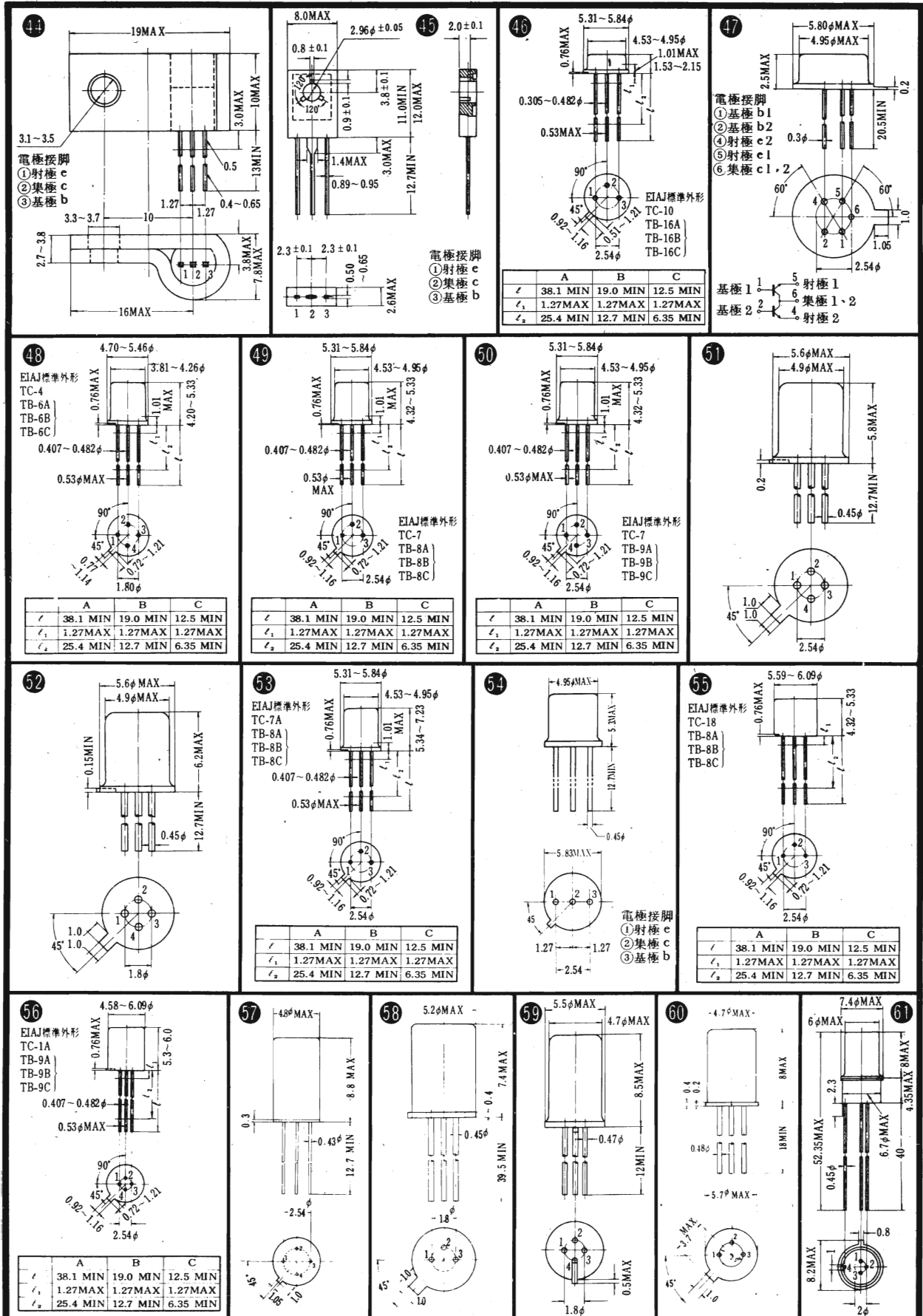

• 管脚接法無註明時，為①射極、②集極、③集極、④屏蔽電極。

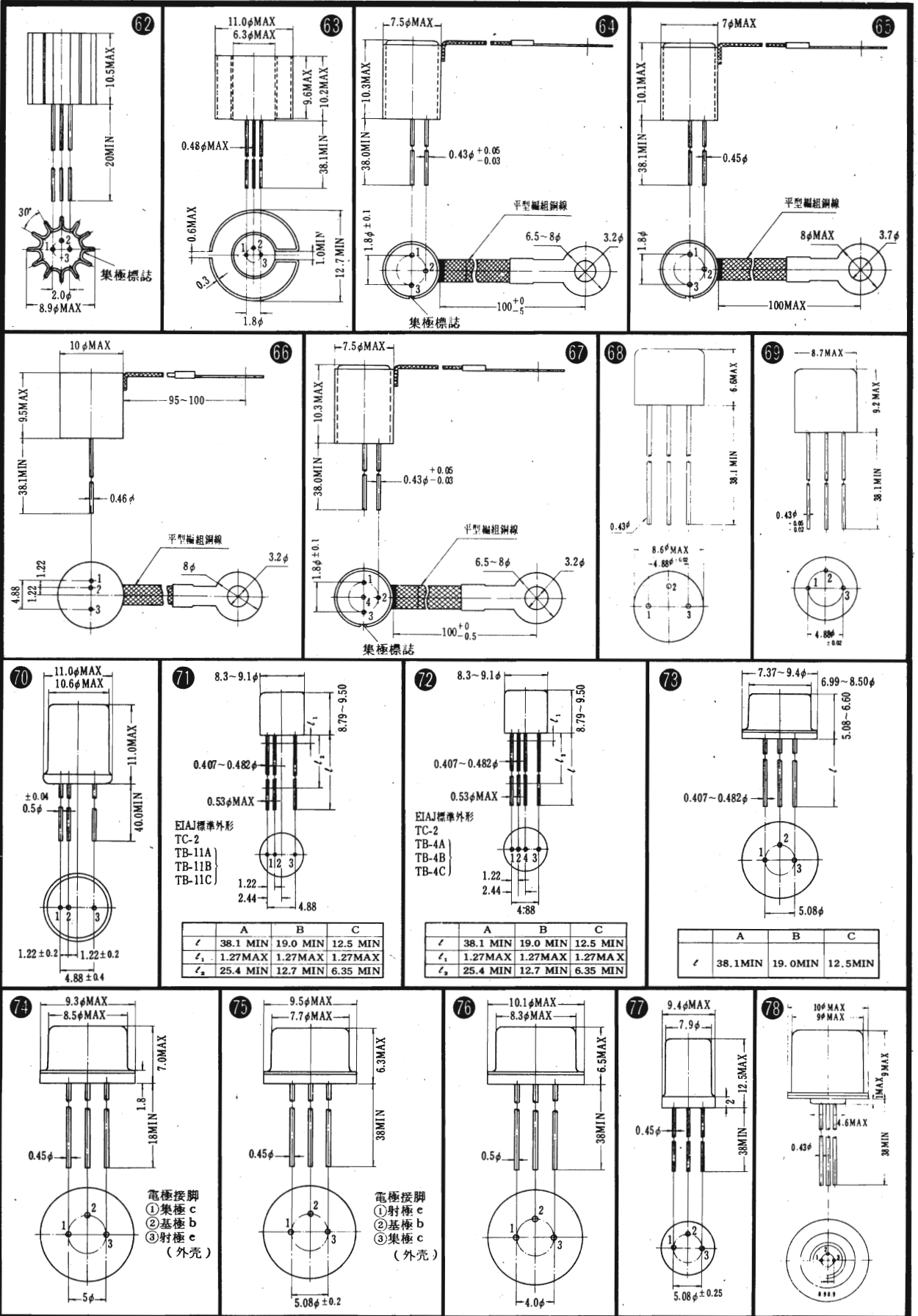

• 管脚接法無註明時，為①射極、②基極、③集極、④屏蔽電極。

◀◀ 尺寸圖單位：mm ▶▶

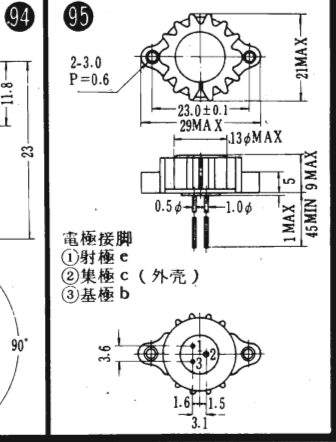
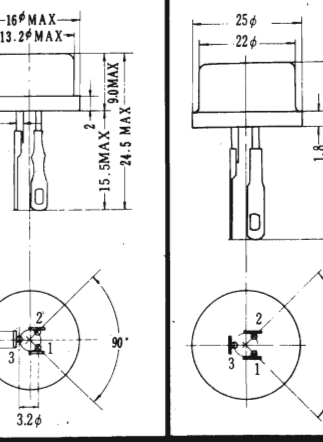
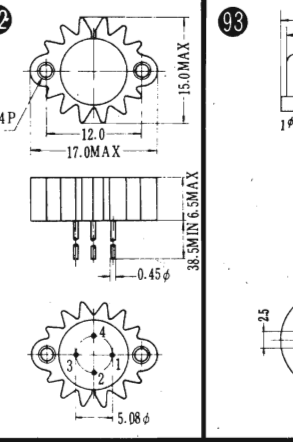
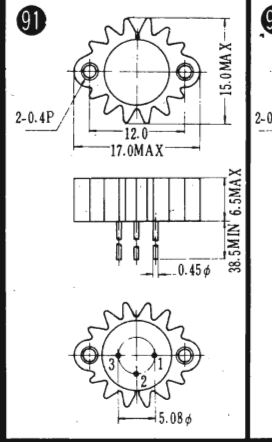
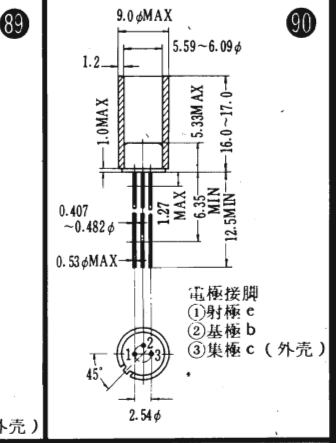
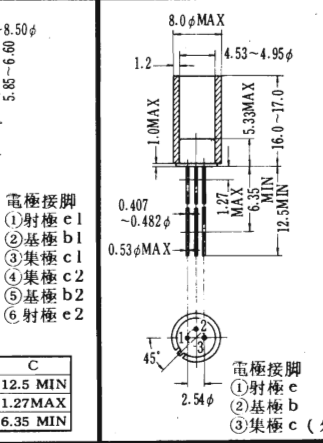
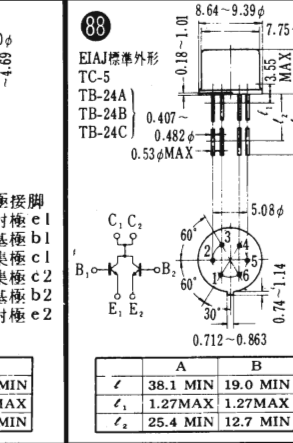
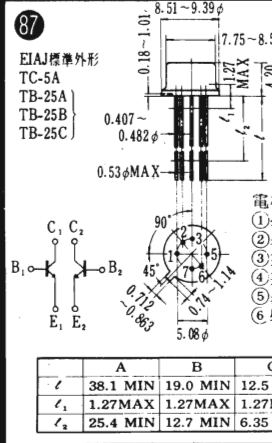
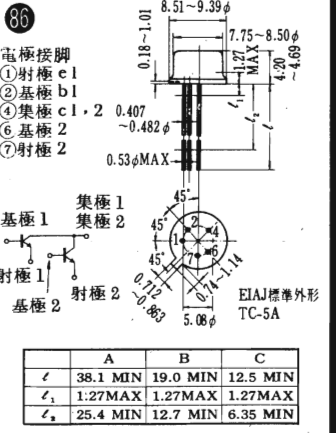
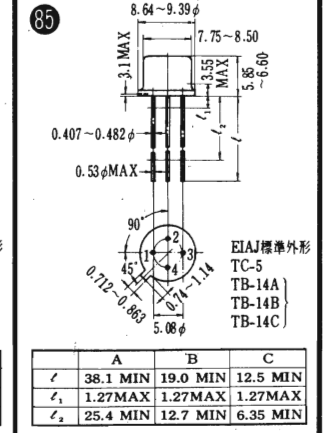
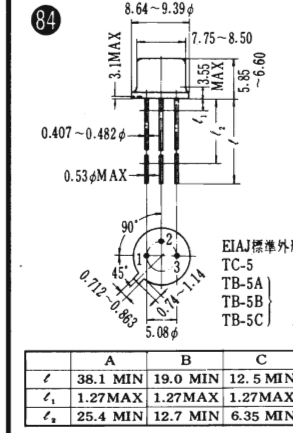
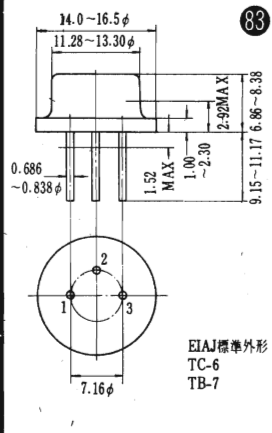
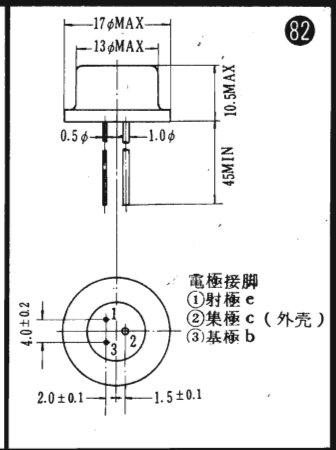
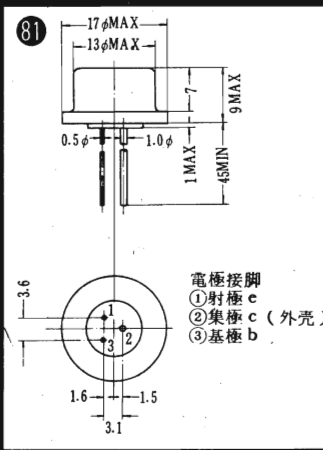
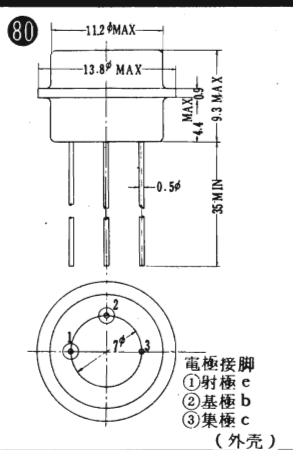
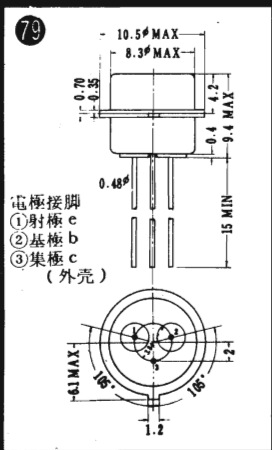

• 管脚接法無註明時，為①射極、②基極、③集極、④屏蔽電極。

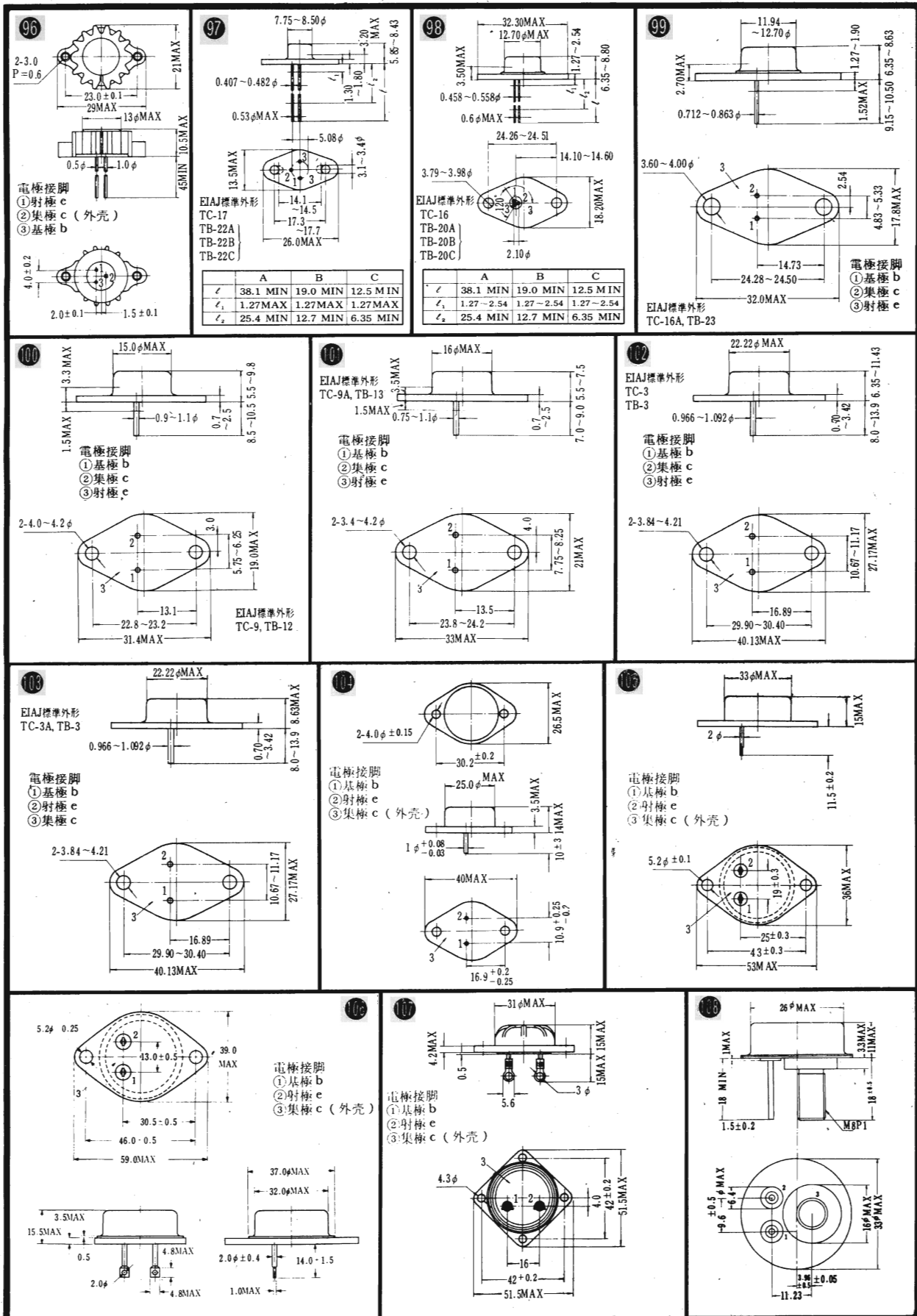

• 管脚接法無註明時，為①射極、②基極、③集極、④屏蔽電極。

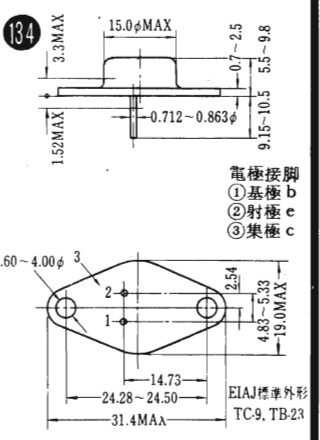
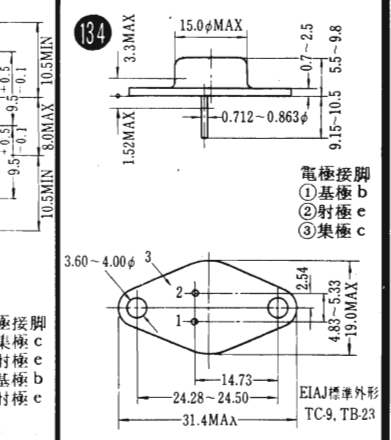
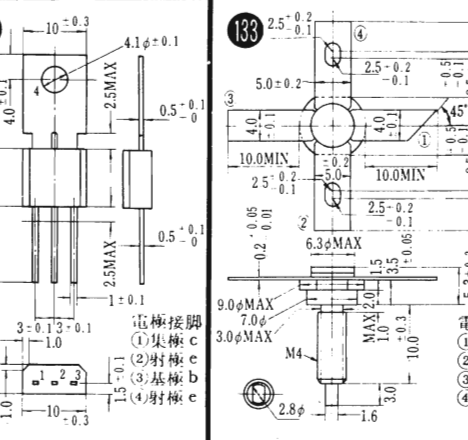
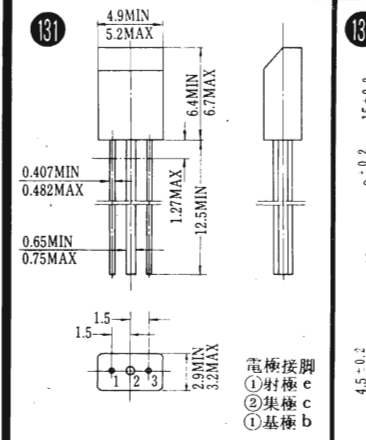
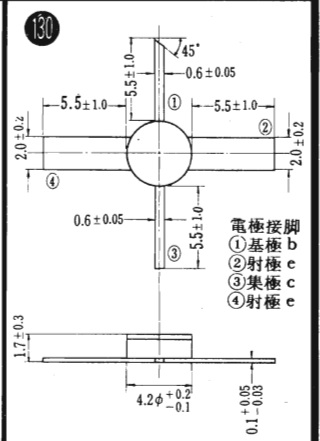
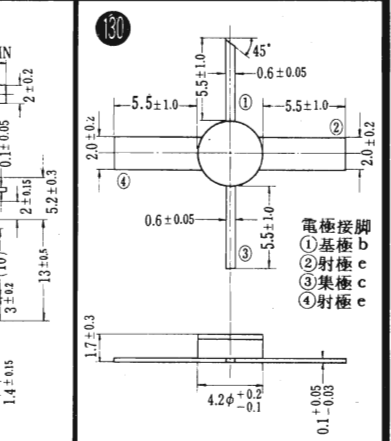
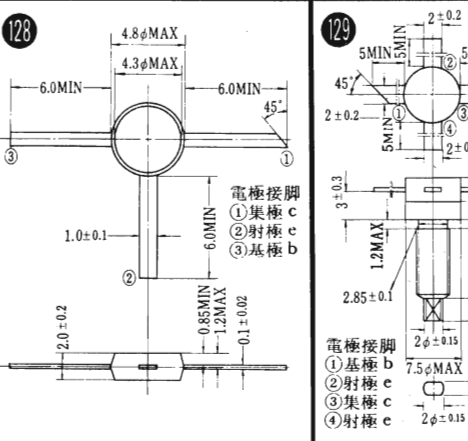
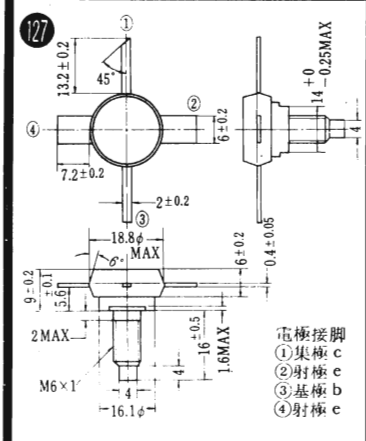
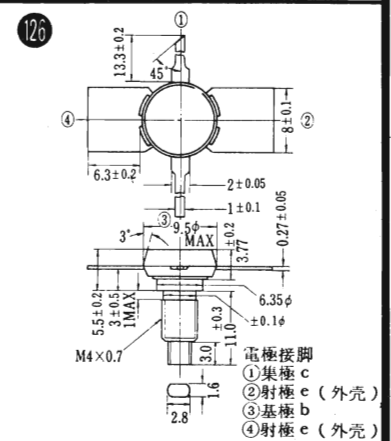
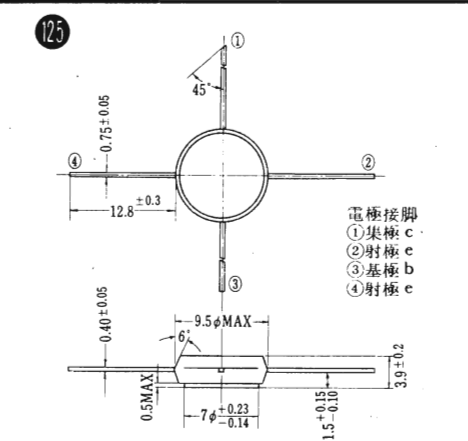
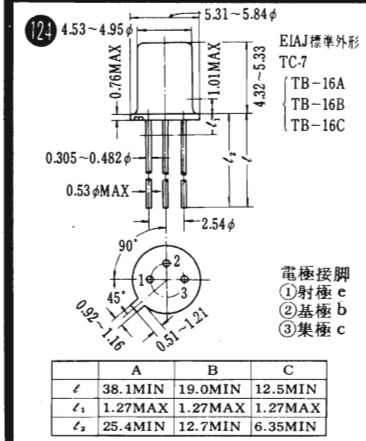
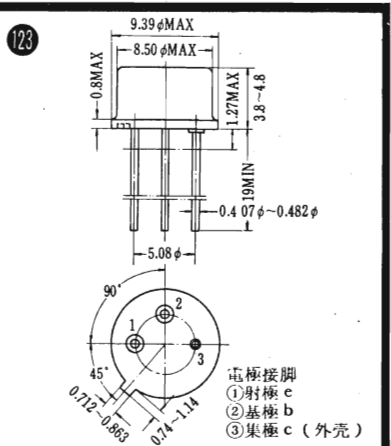
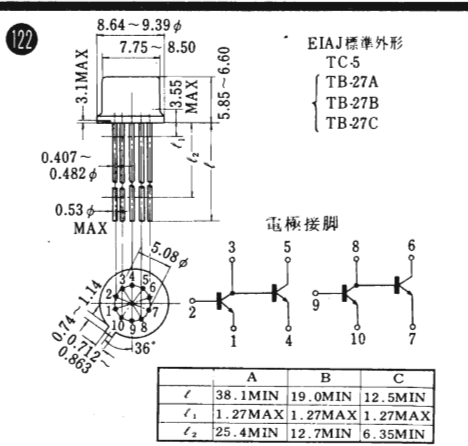
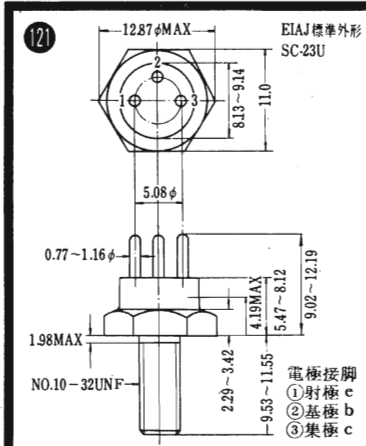

• 管腳接法無註明時，為①射極、②基極、③集極、④屏蔽電極。

◀ 尺寸圖單位：mm ▶

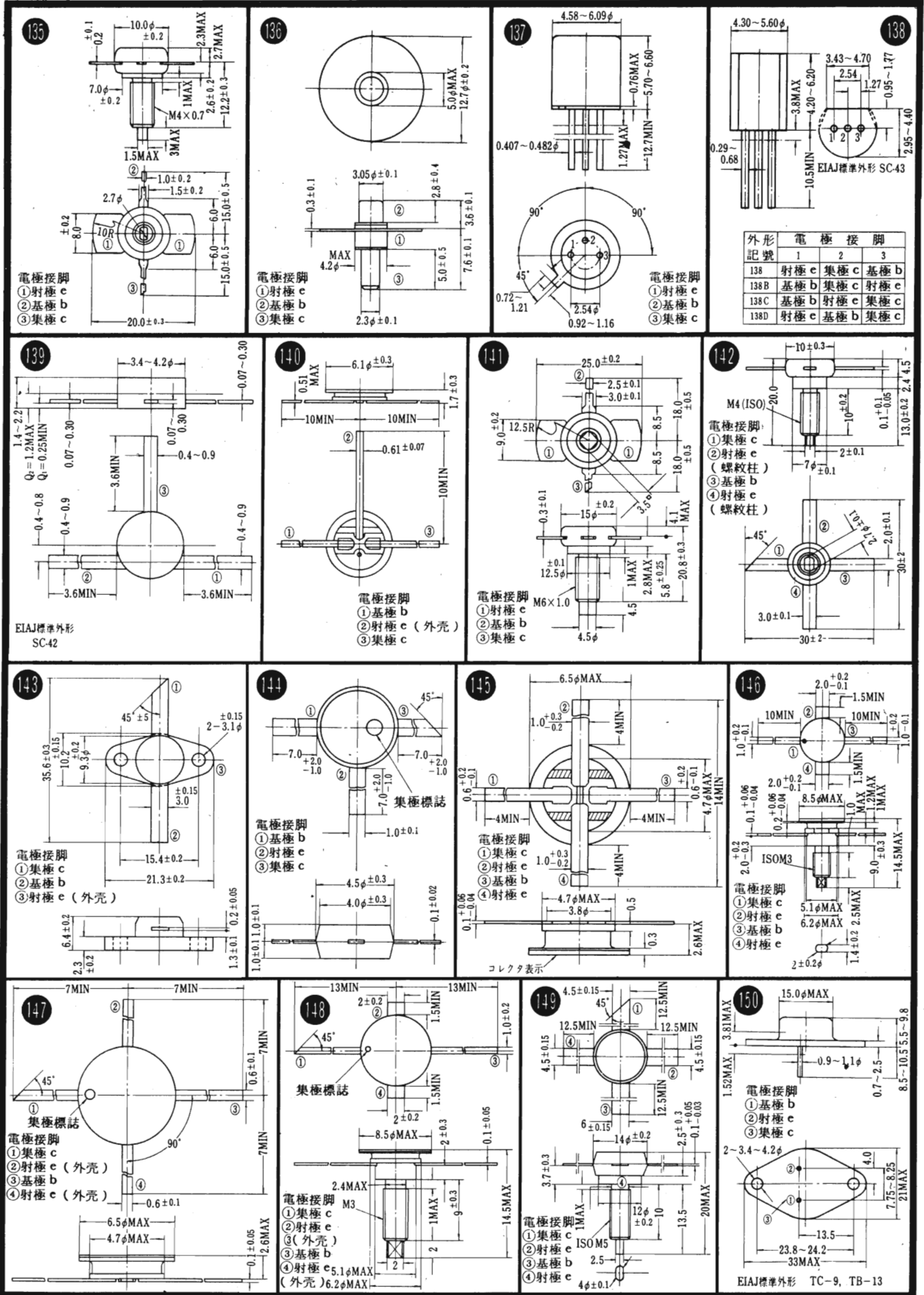

• 管脚接法無註明時，爲①射極、②基極、③集極、④屏蔽電極。

◀ 尺寸圖單位：mm ▶

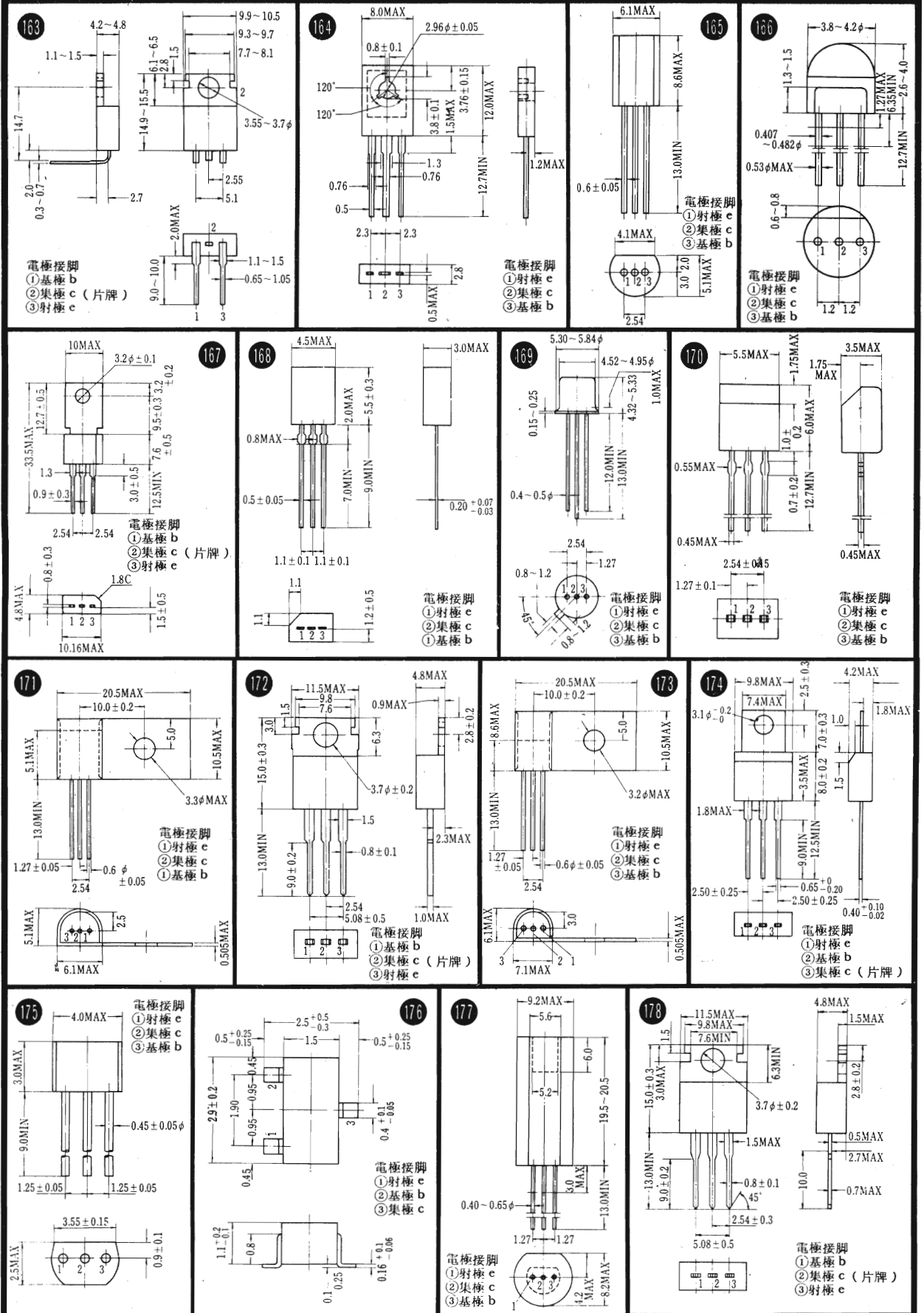

• 管脚接法無註明時，爲①射極、②基極、③集極、④屏蔽電極。

◀◀ 尺寸圖單位：mm ▶▶

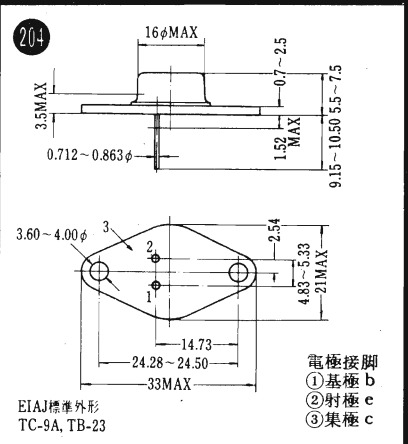
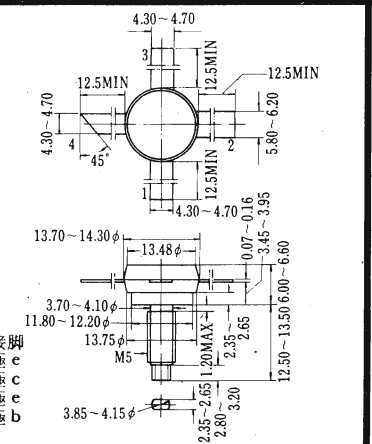
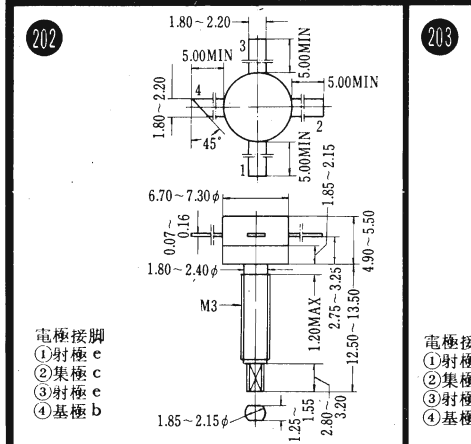
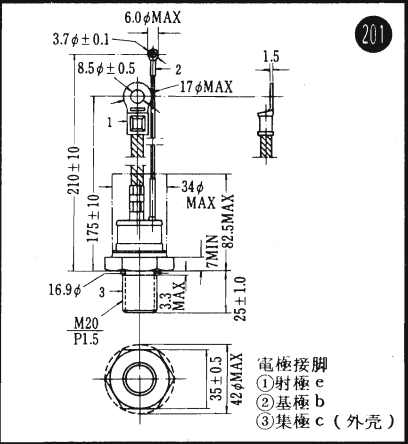
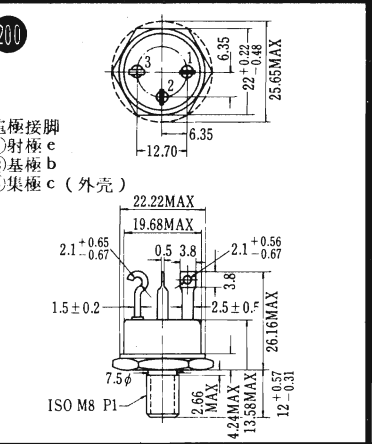
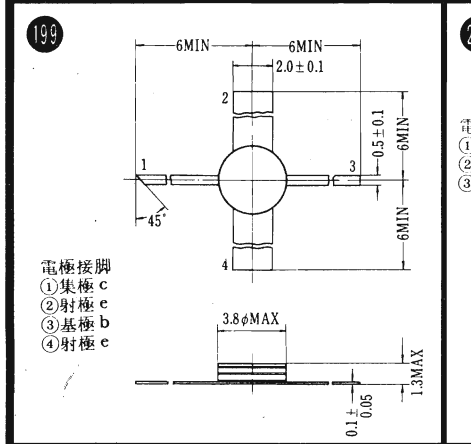
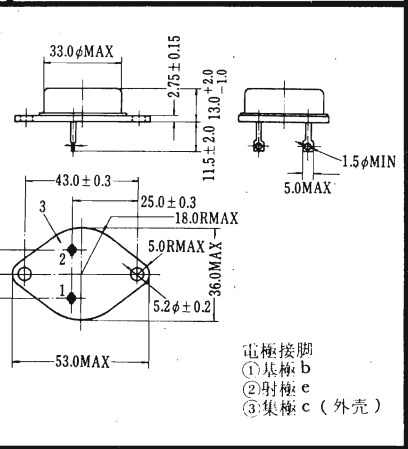
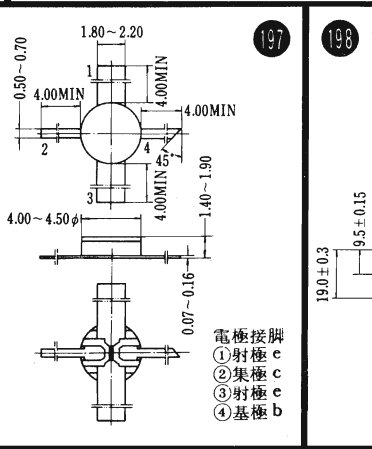
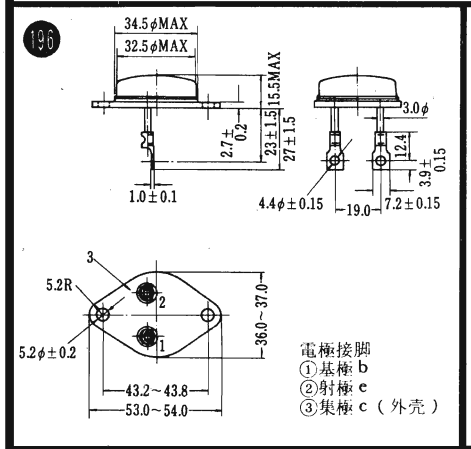
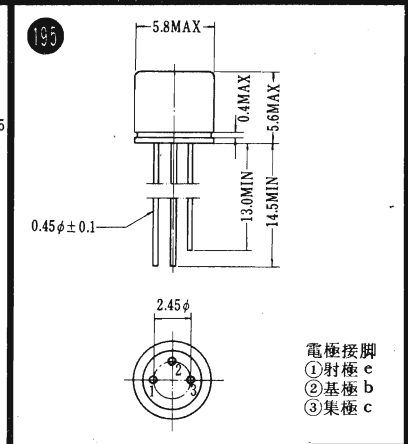
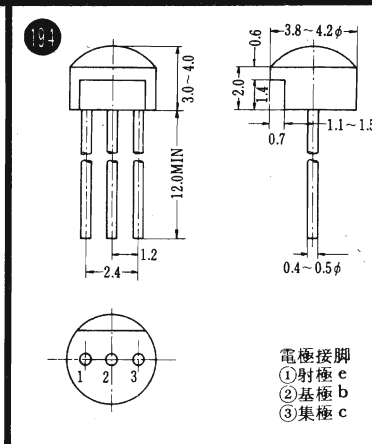
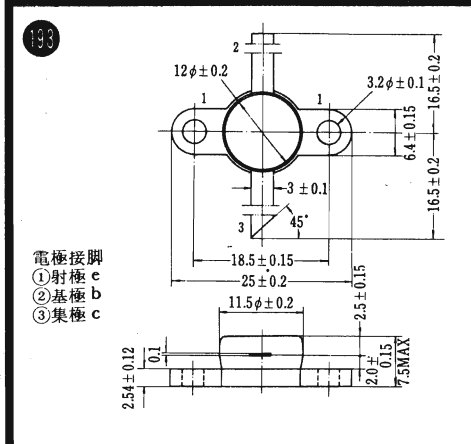

205

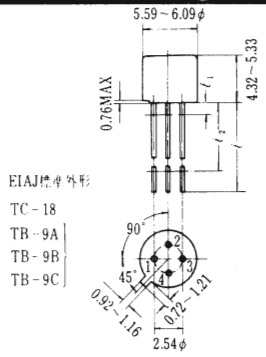

EIAJ標準外形
TC-18
TB-9A
TB-9B
TB-9C

	A	B	C
/	38.1MIN	19.0MIN	12.5MIN
/ ₁	1.27MAX	1.27MAX	1.27MAX
/ ₂	25.4MIN	12.7MIN	6.35MIN

206

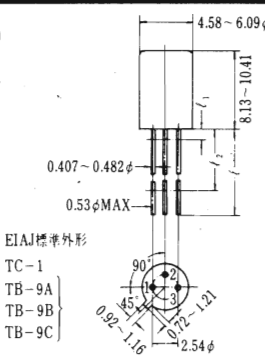

EIAJ標準外形
TC-1
TB-9A
TB-9B
TB-9C

	A	B	C
/	38.1MIN	19.0MIN	12.5MIN
/ ₁	1.27MAX	1.27MAX	1.27MAX
/ ₂	25.4MIN	12.7MIN	6.35MIN

207

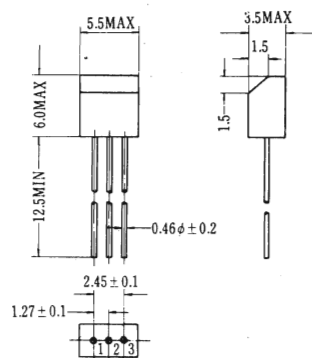

208

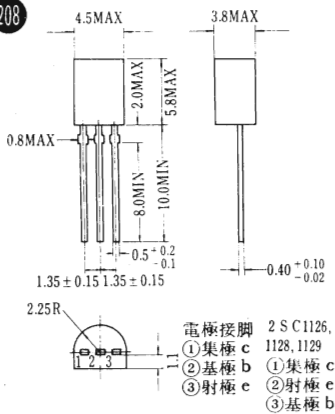

電極接脚 2 S C 1126,
①集極 c 1128, 1129
②集極 b ①集極 c
③射極 c ②射極 c
④基極 b

209

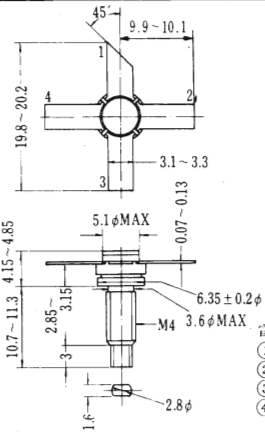

電極接脚
①集極 c
②射極 c
③基極 b
④射極 c

210

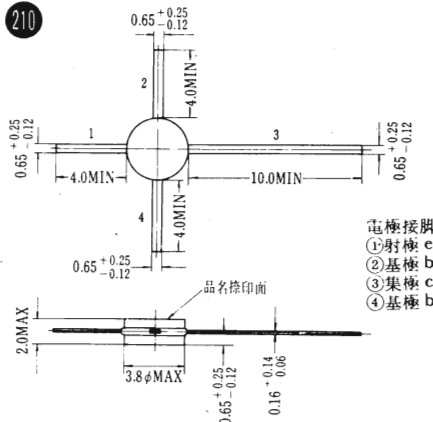

電極接脚
①射極 c
②基極 b
③集極 c
④基極 b

211

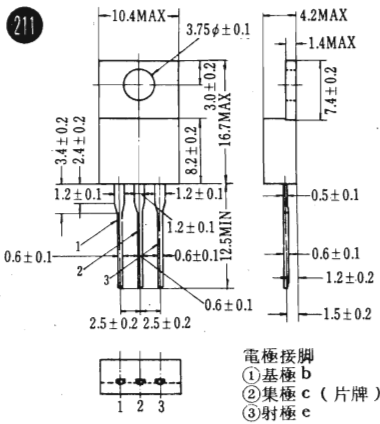

電極接脚
①基極 b
②集極 c (片牌)
③射極 c

212

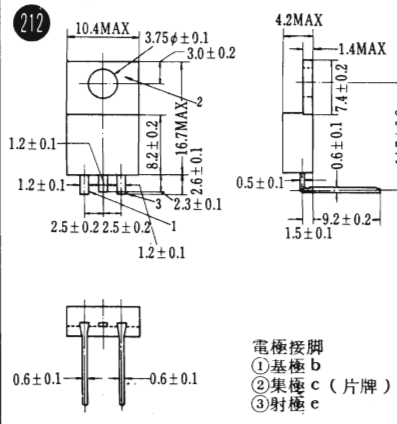

電極接脚
①基極 b
②集極 c (片牌)
③射極 c

213

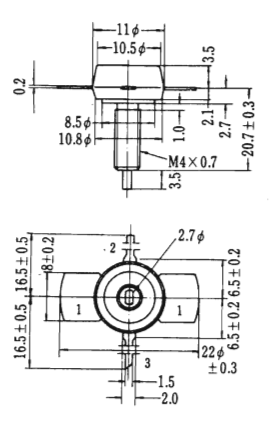

214

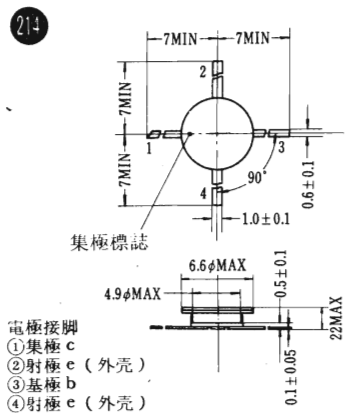

電極接脚
①集極 c
②射極 c (外壳)
③基極 b
④射極 c (外壳)

215

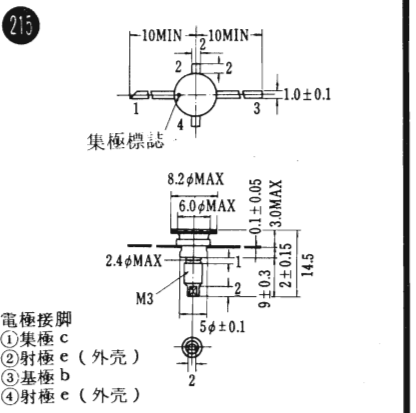

電極接脚
①集極 c
②射極 c (外壳)
③基極 b
④射極 c (外壳)

216

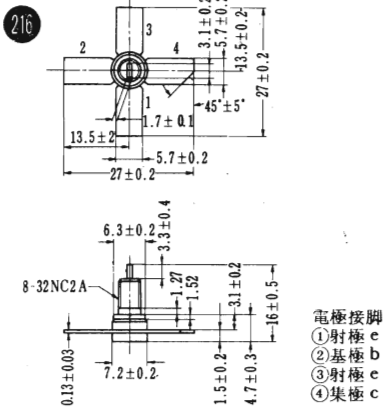

電極接脚
①射極 c
②基極 b
③射極 c
④集極 c

• 管脚接法無註明時，為①射極、②基極、③集極、④屏蔽電極。

217

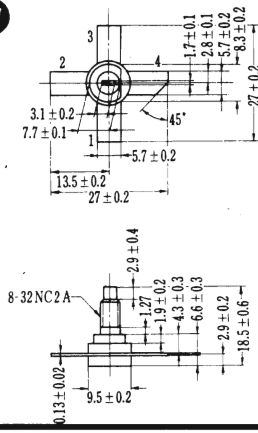

電極接脚
①集極 c
②基極 b
③射極 e
④集極 c

218

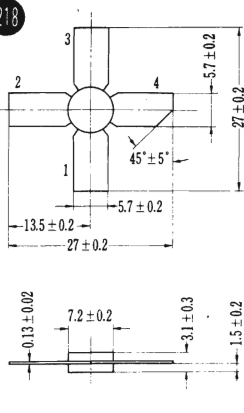

電極接脚
①集極 c
②基極 b
③射極 e
④集極 c

219

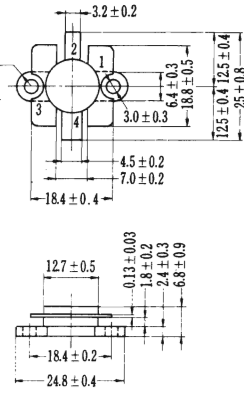

電極接脚
①集極 c
②基極 b
③射極 e
④集極 c

220

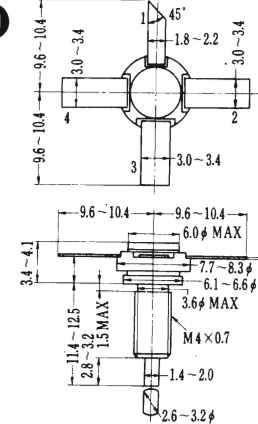

電極接脚
①集極 c
②射極 e
③基極 b
④射極 e

221

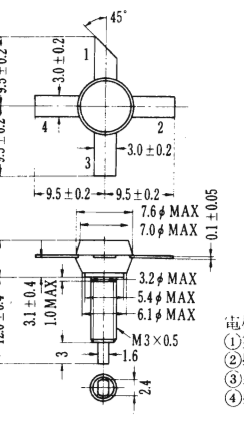

電極接脚
①集極 c
②射極 e
③基極 b
④射極 e

222

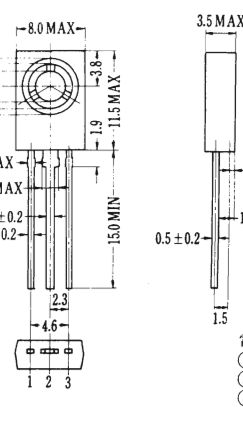

電極接脚
①射極 e
②集極 c
③基極 b

223

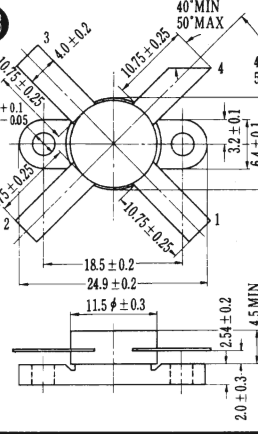

電極接脚
①二極管陽極
②基極 b
③射極兼二極管陰極
④集極 c

224

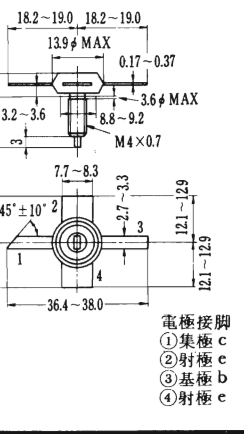

電極接脚
①集極 c
②射極 e
③基極 b
④射極 e

225

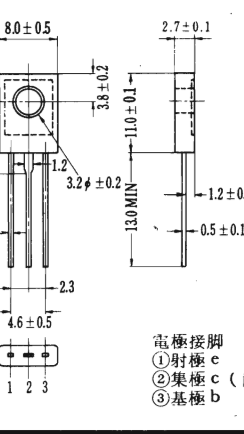

電極接脚
①射極 e
②集極 c (散熱板)
③基極 b

226

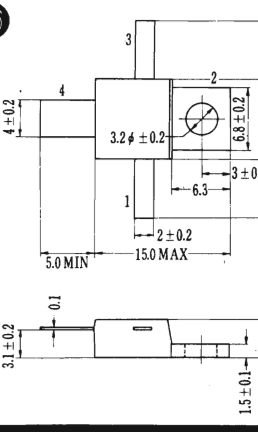

電極接脚
①基極 b
②集極 c (片牌)
③射極 e

227

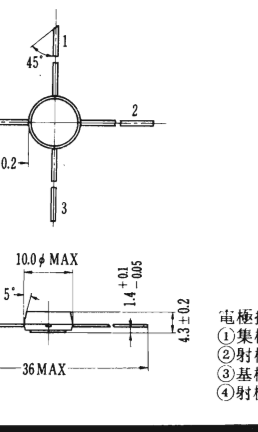

電極接脚
①集極 c
②射極 e
③基極 b
④射極 e

228

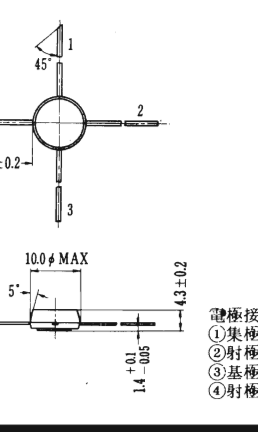

電極接脚
①集極 c
②射極 e
③基極 b
④射極 e

・管脚接法無註明時，爲①射極、②基極、③集極、④屏蔽電極。

◀◀ 尺寸圖單位：mm ▶▶

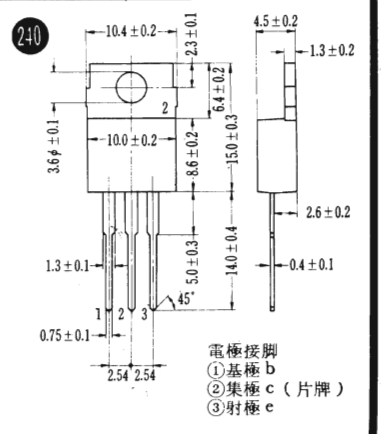
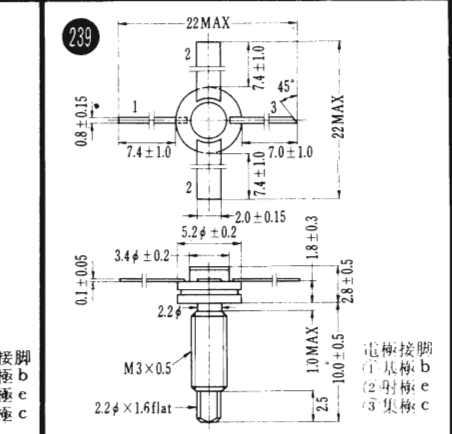
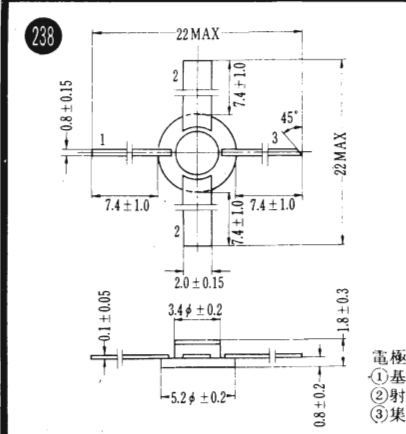
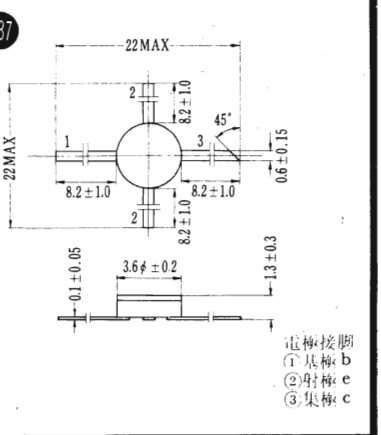
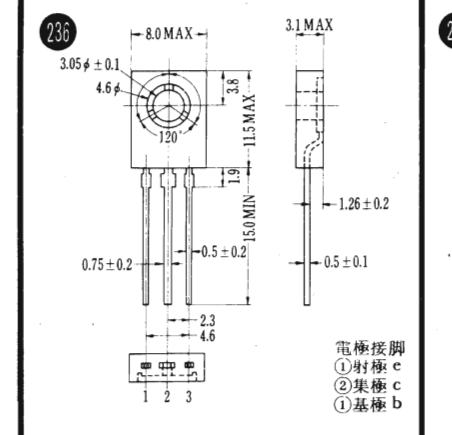
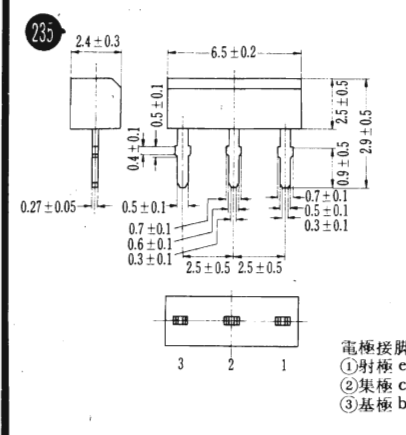
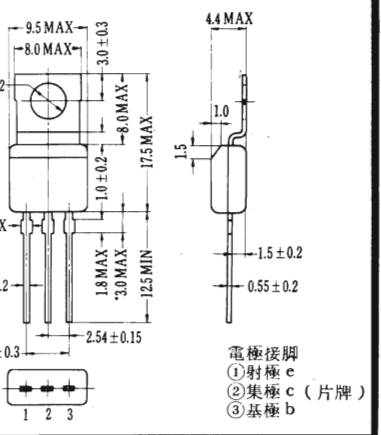
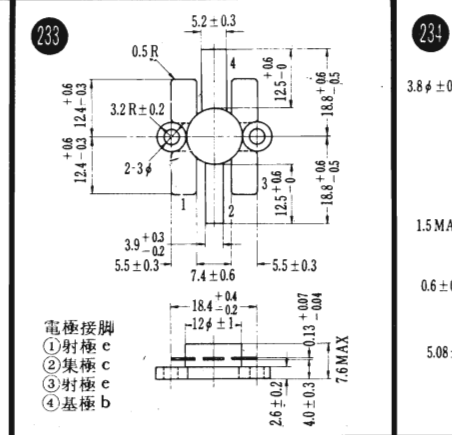
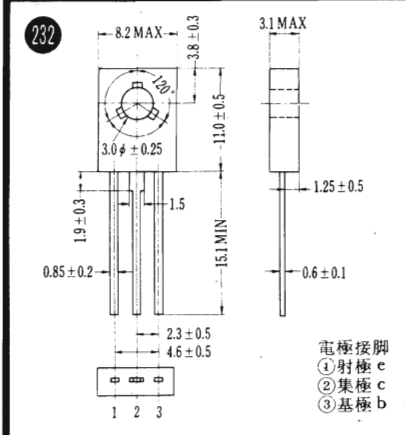
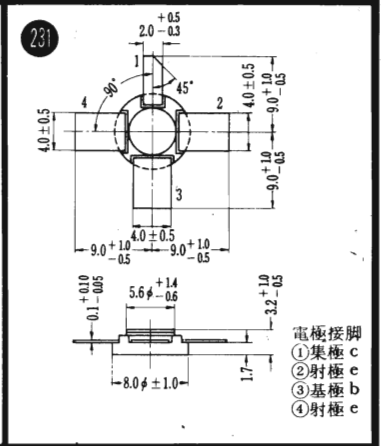
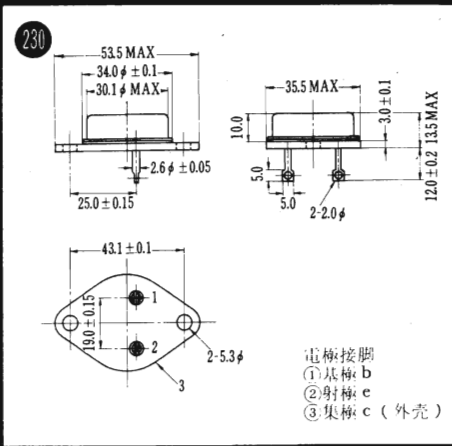
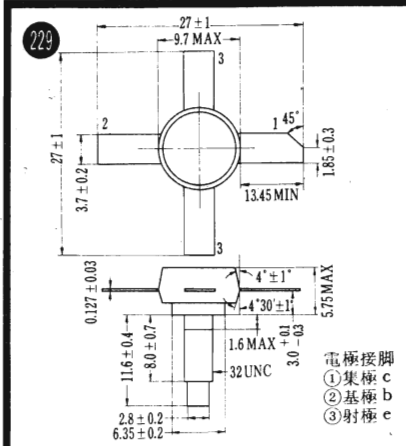

• 電脚接法無註明時，為①射極、②基極、③集極、④屏蔽電極。

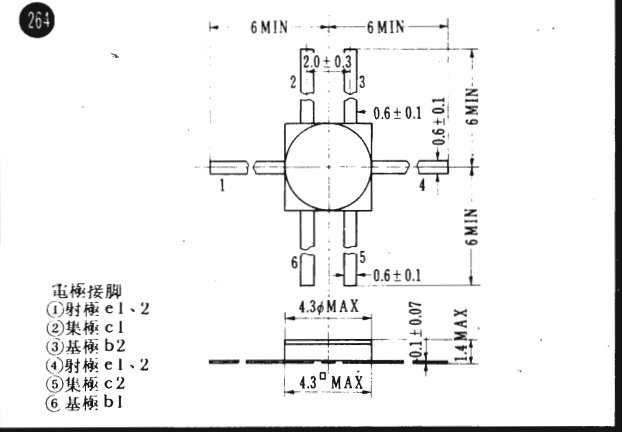
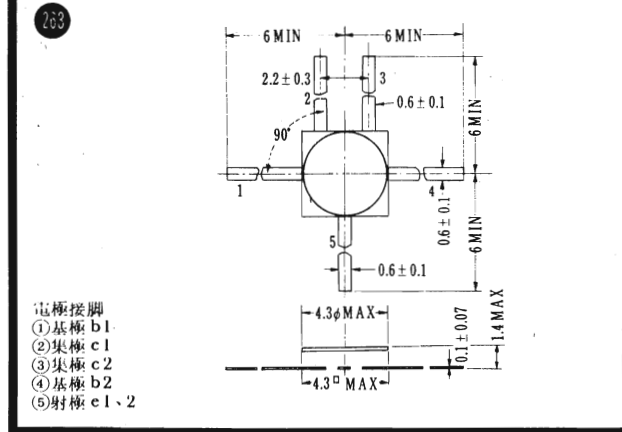
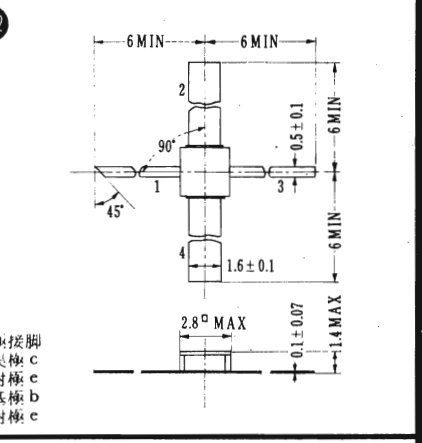
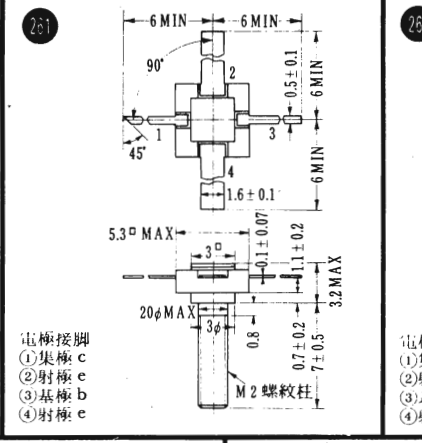
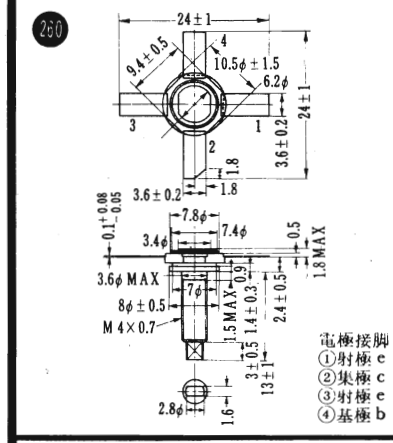
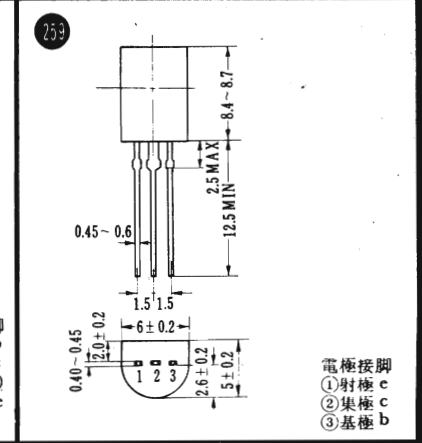
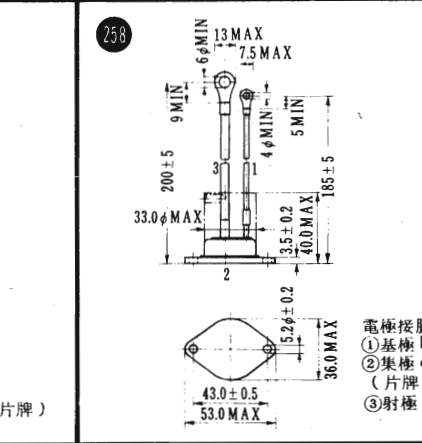
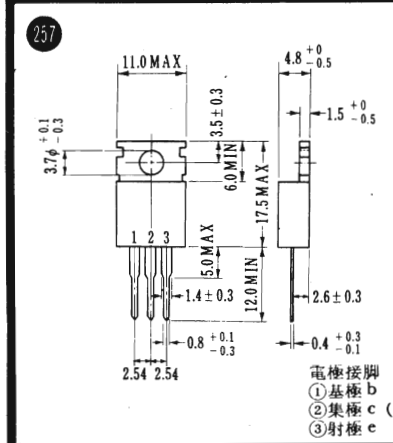
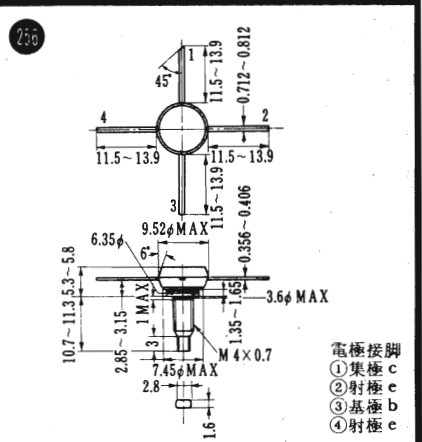
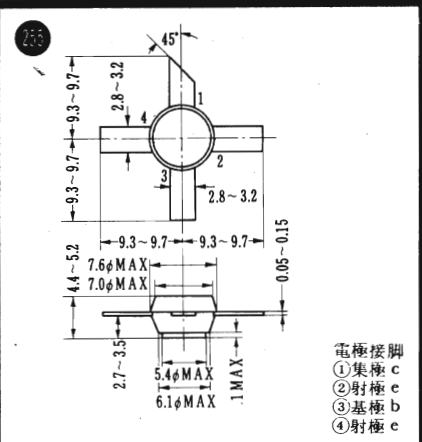
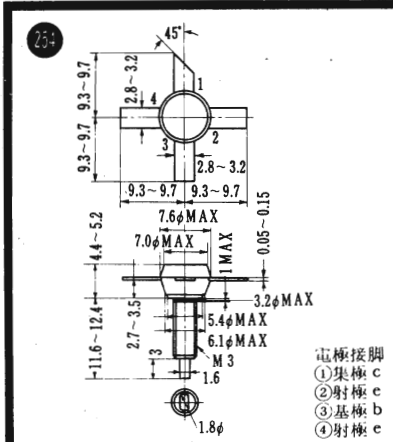

• 管脚接法無註明時，為①射極、②基極、③集極、④屏蔽電極。

有關晶體管及FET原理、使用、 測試及資料的參攷文章

- ① 舊料晶體管怎樣測試和分類..... 23 期
- ② 各種晶體管測試方法的比較..... 24 期
- ③ 對裝晶體管匹配選擇器..... 25 期
- ④ 日本利達 LTC-901 晶體管測試器的分析..... 25 期
- ⑤ 場效應晶體管的性能和使用(上)(下)..... 29—30 期
- ⑥ 日置電機晶體管測試附加器的結構分析..... 29 期
- ⑦ 可靠易裝的晶體管測試器..... 31 期
- ⑧ RCA 設計巧妙的晶體管曲綫描繪附加裝置..... 32 期
- ⑨ 發射機功率放大級晶體管的匹配與選用..... 35—36 合刊
- ⑩ 簡單場效應晶體管試驗器..... 35—36 合刊
- ⑪ 常用歐美晶體管引綫識別(上)(下)..... 35—36 合刊及 37 期
- ⑫ 歐美晶體管分類特性表(一)~(十)..... 38~47 期
- ⑬ MOSFET 的原理與認識..... 39 期
- ⑭ 彩色大頁——日本晶體管用途分類表(上)(下)..... 39~40 期
- ⑮ 晶體管快速測試儀..... 43 期
- ⑯ 半導體器件全能試驗器(上)(下)..... 44~45 期
- ⑰ 怎樣選擇電路上所用的晶體管..... 47 期

上述各期目前均有存書，請來信香港九龍中央郵局信箱K-4318號無線電製作補購，34期及以前，每本1.7元；46期及以前每本2.2元；47期起每本2.7元。上述已包括郵費在內。

為你解決一切晶體管及FET選用上的困難

或許你也不應缺少這一本

TYPE	C	P	F	EUR	EUR	EUR	AM	AM	JAP
BSY75	S	N	E	BFV23	BSX51A	最新場效應晶體管對換表			
BSY76	S	N	E	BCY89VII	BSX45	管號 可代用管 管號 可代用管			
BSY76B	S	N	E	BFY12C	BSX45				
BSY77	S	N	E	BC108A	BSX45				
	S	N	E	BFY34	BSX45				
	S	N	E	BCY65E	BSY56				
BSY78	S	N	E	BFY46	BSX45				
BSY79	S	N	E	BFY45	BFY90				
BSY80	S	N	E	BC108	BC100				
BSY81	S	N	E	BCY88VIII	BC130C				
BSY82	S	N	E	BSX45-6	BSX72				
	S	N	E	BSX45-10	BSY72				
BSY83	S	N	E	BSY40	BSY46				
BSY84	S	N	E	BSX45-10	BSX45				
BSY85	S	N	E	BSY46	BSX26				
BSY86	S	N	E	BSX46-10	BSX26				
BSY87	S	N	E	BFY14C	BC141-6				
BSY88	S	N	E	BFY14D	BC141-10				
BSY89	S	N	E	BSY46	BSX26				
BSY90	S	N	E	BFY46	BC140-10				
BSY91	S	N	E	BFY33	BSX26				
	S	N	E	BSX48	BSX48				
BSY92	S	N	E	BFY34	BSX45-6				
BSY93	S	N	E	BCY65E	BSY56				
BSY95A	S	N	E	BSX73	BSY56				
BSY148A	S	N	E	BSY82	BSY82				
BSY148B	S	N	E	BSX68	BSY82				
	S	N	E	BSX67	BSY82				
BSY152A	S	N	E	BSX19	BSY82				
BSY152B	S	N	E	BSX20	BSY82				
BU100	S	N	E	BSX68	BSY82				
BU102	S	N	E	BSX68	BSY82				
BU103A	S	N	E	BSX68	BSY82				
BU104	S	N	E	BU108	BU108				
BU108	S	N	E	BU108	BU108				
BU109	S	N	E	BU108	BU108				
BU110	S	N	E	BU108	BU108				
BU111	S	N	E	BU126	BU126				

這是一份行銷歐洲、美國及日本，原由六國文字印成的全世界晶體管換用手冊，內容包括了歐洲、美國及日本所出品的 12,500 個編號晶體管的互為代換，順序臚列為 56,000 欄的代換方式。

本刊將之分成八輯出版，並印成袖珍口袋裝的形式，便於攜帶。也增加了取自其他資料來源的截止至 1975 年之最新代換品種，以及場效應管的代換。

有了這八輯的代用表，再配合 1975 年增刊的全日本晶體管一場效應管特性資料與換用手冊，相信對製作中或設計時所遭遇到的購買上及選用上的問題，都可一一解決。八輯換用表的購買方式，可依下述方法辦理：

本港讀者——寄來一個寫上地址及貼上回郵郵票（二角），並附八輯之費用共四元。

外埠讀者——寄來一個寫上地址，但不用貼上郵票的回郵信封，並附八輯之費用四元及空郵寄費一元。（即共為星馬幣 2.5 元或新台幣 40 元或美鈔 1 元）

無線電製作 香港九龍中央郵局信箱 K-4318 號

The Radio Experimenter G. P. O. Box K-4318, Kowloon
Central Post Office, Hong Kong.

美、日、英、歐最新晶體管換用表

無線電製作

電製作

一九七五年十一月十五日